

1. Select the correct response for the missing reason in the algebraic proof below.

Given: $2(x + 5) - 3x = 7$

Prove: $x = 17$

Statements	Reasons
1. $2(x + 5) - 3x = 7$	1. Given
2. $2x + 10 - 3x = 7$	2. Circle One: <ul style="list-style-type: none"> • Addition Property of Equality • Subtraction Property of Equality • <input checked="" type="radio"/> Distributive Property • Combine like terms / Simplify
3. $-x + 10 = 7$	3. Combine like terms / Simplify
4. $-x = -17$	4. Subtraction Property of Equality
5. $x = 17$	5. Division Property of Equality

2. Select the correct response for the missing reason in the geometric proof below.

Given:

- $\overline{MP} \cong \overline{LP}$
- $\overline{LN} \cong \overline{MO}$

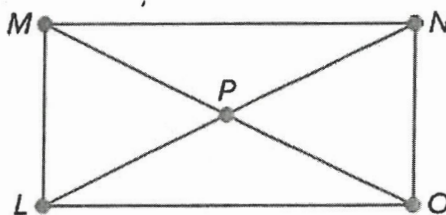

Prove: $PN = PO$

Statements	Reasons
1. $\overline{MP} \cong \overline{LP}; \overline{LN} \cong \overline{MO}$	1. Given
2. $MP = LP; LN = MO$	2. Definition of Congruent
3. $MO = MP + PO; LN = LP + PN$	3. Segment Addition Postulate
4. $LP + PN = MP + PO$	4. Substitution Property of Equality
5. $LP + PN = LP + PO$	5. Substitution Property of Equality
6. $PN = PO$	6. Circle One: <ul style="list-style-type: none"> • Definition of Congruent • Segment Addition Postulate • <input checked="" type="radio"/> Subtraction Property of Equality • Substitution Property of Equality • Reflexive Property of Equality

3. Use the word banks below to complete the paragraph proof.

Given: $\overline{AB} \cong \overline{FG}$; $\overline{BC} \cong \overline{EF}$

Prove: $\overline{AC} \cong \overline{EG}$

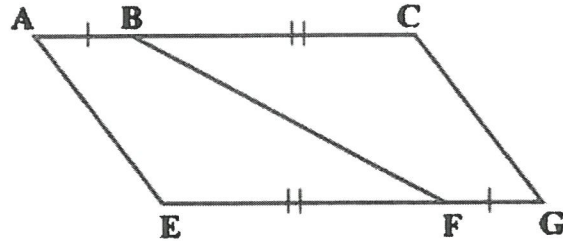

We are given that $\overline{AB} \cong \overline{FG}$ and $\overline{BC} \cong \overline{EF}$.

$AB = FG$ and $BC = EF$ by the definition of congruence.

By the 1, $AB + BC = AC$ and $EF + FG = EG$.

By the substitution property of equality, $AB + BC = EG$.

By the 2 of equality, $AC = EG$; therefore, by the definition of congruence, $\overline{AC} \cong \overline{EG}$.

Handwritten in pink:
 $EG = AB + BC$
 (A line connects the '1' in the previous step to the '2' in this step, passing through the handwritten equation.)

Blank #1	Blank #2
angle addition postulate segment addition postulate definition of complementary angles definition of supplementary angles	transitive property addition property reflexive property symmetric property

4. Select the correct responses for the missing statements or reasons in the geometric proof below.

Given:

- $X, Y,$ and Z are collinear.
- Y is between X and Z .
- $XY = 2x + 2$
- $YZ = 5x - 3$
- $XZ = 34$

Prove: $YZ = 22$

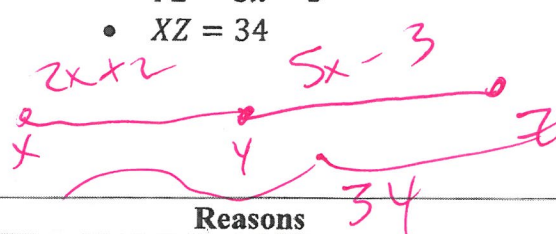

Statements	Reasons
1. $X, Y,$ and Z are collinear; Y is between X and Z .	1. Given
2. $XZ = XY + YZ$	2. Circle One: <ul style="list-style-type: none"> • Addition Property of Equality • Circle One: Segment Addition Property • Substitution Property of Equality • Transitive Property of Equality
3. $XY = 2x + 2; YZ = 5x - 3; XZ = 34$	3. Given
4. $2x + 2 + 5x - 3 = 34$	4. Circle One: <ul style="list-style-type: none"> • Addition Property of Equality • Segment Addition Property • Circle One: Substitution Property of Equality • Transitive Property of Equality
5. Circle One: <ul style="list-style-type: none"> • $7x - 5 = 34$ • Circle One: $7x - 1 = 34$ • $3x - 5 = 34$ • $3x - 1 = 34$ 	5. Combine Like Terms / Simplify
6. $7x = 35$	6. Circle One: <ul style="list-style-type: none"> • Circle One: Addition Property of Equality • Subtraction Property of Equality • Multiplication Property of Equality • Division Property of Equality
7. ($x = 3; x = 4; x = 5; x = 6; x = 7$)	7. Division Property of Equality
8. $YZ = 5(5) - 3$	8. Circle One: <ul style="list-style-type: none"> • Addition Property of Equality • Multiplication Property of Equality • Circle One: Substitution Property of Equality • Combine Like Terms/Simplify
9. $YZ = 22$	9. Circle One: <ul style="list-style-type: none"> • Addition Property of Equality • Multiplication Property of Equality • Transitive Property of Equality • Circle One: Combine Like Terms/Simplify

5. In the diagram, $\overline{AB} \cong \overline{CD}$ and $\overline{CD} \cong \overline{BF}$.

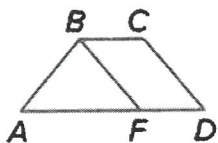

Examine the conclusions made by Leslie and Shantice. Is either of them correct?

Leslie

Because $\overline{AB} \cong \overline{CD}$ and
 $\overline{CD} \cong \overline{BF}$, $\overline{AB} \cong \overline{BF}$ by
 the Transitive Property
 of Congruence.

Shantice

Because $\overline{AB} \cong \overline{CD}$ and
 $\overline{CD} \cong \overline{BF}$, $\overline{AB} \cong \overline{BF}$ by
 the Reflexive Property of
 Congruence.

- A. Leslie is correct; in Shantice's response, $\overline{AB} \cong \overline{BF}$ is by the Transitive property of Congruence.
- B. Shantice is correct; in Leslie's response, $\overline{AB} \cong \overline{BF}$ by the Reflexive Property of Congruence.
- C. Neither are correct, in Shantice's response, $\overline{AB} \cong \overline{BF}$ is by the Transitive property of Congruence and in Leslie's response, $\overline{AB} \cong \overline{BF}$ by the Reflexive Property of Congruence.
- D. Neither are correct, in Shantice's response, $\overline{AB} \cong \overline{BF}$ is by the Transitive property of Congruence and in Leslie's response, we cannot prove $\overline{AB} \cong \overline{BF}$.

1. Find the measure of XZ if Y is between X and Z .

- $XY = 11$
- $YZ = 72$

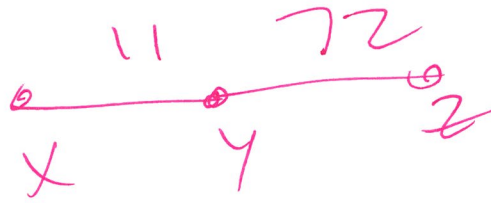

$XZ = \underline{83}$

2. Find the coordinates of M , the midpoint of \overline{AB} .

- $A(-6, 1)$
- $B(4, -9)$

• The coordinates of the midpoint M are: $(\underline{-1}, \underline{-4})$

3. Find the measure of UX .

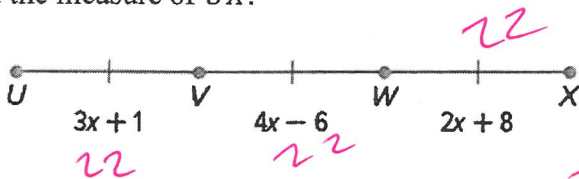

$22 \times 3 = 66$

- A. 3
- B. 7
- C. 21
- D. 22
- E. 42
- F. 44
- G. 63
- H. 66

$3x + 1 = 2x + 8$
 $x = 7$

4. Find the coordinates of the missing endpoint, C , if B is the midpoint of \overline{AC} and if $A(2,1)$ and $B(10,4)$

• The coordinates of the missing endpoint C are: $(\underline{18}, \underline{7})$

graph

$\frac{2+x}{2} = 10$

$2+x = 20$
 $x = 18$

$\frac{1+y}{2} = 4$

$1+y = 8$
 $y = 7$

1. Select the correct response for the missing reason in the algebraic proof below.

Given: $-4x + 6 > 2x - 18$

Prove: $x < 4$

Statements	Reasons
1. $-4x + 6 > 2x - 18$	1. Given
2. $-6x + 6 > -18$	2. Circle One: <ul style="list-style-type: none"> • Addition Property of Inequality • Subtraction Property of Inequality • Distributive Property • Combine like terms / Simplify
3. $-6x > -24$	3. Subtraction Property of Inequality
4. $x < 4$	4. Division Property of Inequality

2. Select the correct responses for the missing reason in the geometric proof below.

Given: $\angle 1 \cong \angle 4$

Prove: $\angle 2 \cong \angle 3$

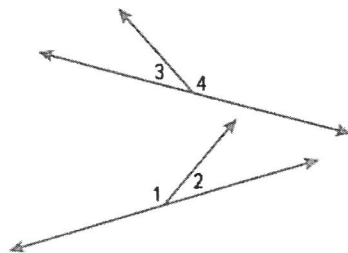

Statements	Reasons
1. $\angle 1$ & $\angle 2$ are a linear pair; $\angle 3$ & $\angle 4$ are a linear pair	1. Definition of a linear pair.
2. $\angle 1$ & $\angle 2$ are supplementary; $\angle 3$ & $\angle 4$ are supplementary	2. Two angles forming a linear pair are supplementary
3. $\angle 1 + \angle 2 = 180$; $\angle 3 + \angle 4 = 180$	3. Definition of supplementary.
4. $\angle 1 \cong \angle 4$	4. Given
5. $\angle 2 \cong \angle 3$	5. Circle One: <ul style="list-style-type: none"> • If two angles are congruent, then their complements are congruent. • If two angles are congruent, then their supplements are congruent. • Vertical angles are congruent.

11

3. Select the correct responses for the missing statements or reasons in the geometric proof below.

Given:

- $\angle 1 \cong \angle 3$
- $m\angle 3 = 90^\circ$

Prove: $\angle 2$ & $\angle 4$ are supplementary.

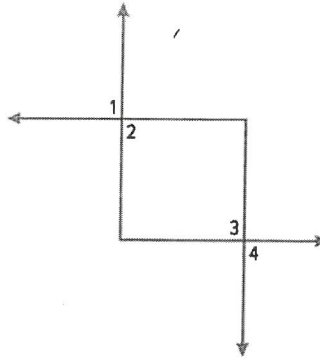

Statements	Reasons
1. $\angle 1 \cong \angle 3; m\angle 3 = 90^\circ$	1. Given
2. $m\angle 1 = m\angle 3$	2. Definition of Congruent
3. $m\angle 1 = 90^\circ$	3. Substitution Property of Equality
4. $m\angle 1 = m\angle 2; m\angle 3 = m\angle 4$	4. Circle One: <ul style="list-style-type: none"> • Symmetric Property of Equality, • Transitive Property of Equality • Reflexive Property of Equality • Vertical angles are congruent • Vertical angles are complementary
5. $m\angle 2 = 90^\circ; m\angle 4 = 90^\circ$	5. Substitution Property of Equality
6. $m\angle 2 + m\angle 4 = 180^\circ$	6. Angle Addition Postulate
7. $\angle 2$ & $\angle 4$ are supplementary	7. Circle One: <ul style="list-style-type: none"> • Definition of Congruent • Definition of Supplementary • Definition of Vertical Angles • Substitution Property of Equality

4. In the figure, parallel lines x and y are cut by transversal p . Complete the proof below.

Given: $x \parallel y$

Prove: $\angle 4 \cong \angle 5$

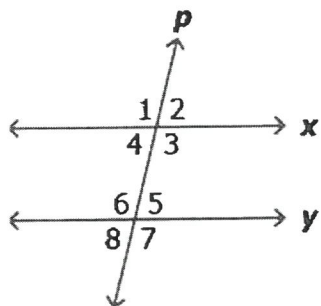

Statements	Reasons
1. $x \parallel y$	1. Given
2. $m\angle 3 + m\angle 4 = 180^\circ$	2. Circle One: <ul style="list-style-type: none"> Two angles forming a linear pair are supplementary. Definition of a linear pair Consecutive interior angles are supplementary. Alternate interior angles are congruent.
3. $m\angle 3 + m\angle 5 = 180^\circ$	3. Circle One: <ul style="list-style-type: none"> Two angles forming a linear pair are supplementary. Definition of a linear pair Consecutive interior angles are supplementary. Alternate interior angles are congruent.
4. Circle One: <ul style="list-style-type: none"> $m\angle 3 + m\angle 5 = 2 \cdot m\angle 3$ $m\angle 4 + m\angle 5 = 180^\circ$ $m\angle 3 + m\angle 4 = m\angle 3 + m\angle 5$ $m\angle 3 + m\angle 4 = 2 \cdot m\angle 3$ 	4. Substitution Property of Equality
5. $m\angle 4 = m\angle 5$	5. Subtraction Property of Equality
6. $\angle 4 \cong \angle 5$	6. Circle One: <ul style="list-style-type: none"> Symmetric property of equality. Definition of congruent Reflexive property of congruence Definition of a linear pair.

135. Students were asked to complete a paragraph proof to prove the statement: "If two congruent angles form a right angle, then they are acute angles."

A student's incorrect answer is below, identify their error.

If two congruent angles, $\angle 1$ & $\angle 2$, form a right angle, then $m\angle 1 + m\angle 2 = 90^\circ$ (Angle Addition Postulate) and $m\angle 1 = m\angle 2$ (definition of congruent).

We can say that $m\angle 1 + m\angle 1 = 90^\circ$ by the Substitution Property of Equality; we can combine like terms/simplify to then have $2 \cdot m\angle 1 = 90^\circ$.

Using the Division Property of Equality our equation is now $m\angle 1 = 45^\circ$.

By the Substitution Property of Equality, $m\angle 2 = 45^\circ$.

Therefore, two congruent angles that form a right angle are both acute angles, by the definition of an acute angle.

Identify the error:

- A. For the phrase $m\angle 1 = m\angle 2$, the reasoning should have been (vertical angles are congruent)
- B. For the phrase $m\angle 1 + m\angle 2 = 90^\circ$, the reasoning should have been (definition of right angle)
- C. Switch the 2nd sentence with the 3rd sentence.
- D. Switch the 3rd sentence with the 4th sentence.
- E. There isn't an error in the student's paragraph proof.

4) 1. Consider the figure below.

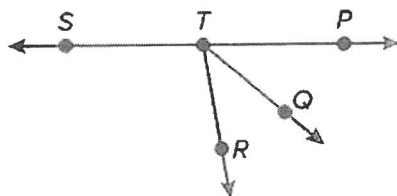

Identify the pair of adjacent angles. Select all that apply.

- A. $\angle STR$ & $\angle QTP$
- B. $\angle STR$ & $\angle RTP$
- C. $\angle PTR$ & $\angle QTR$
- D. $\angle QTR$ & $\angle QTP$

5) 2. In the image, $a \parallel b$. The $m\angle 2 = 150^\circ$.

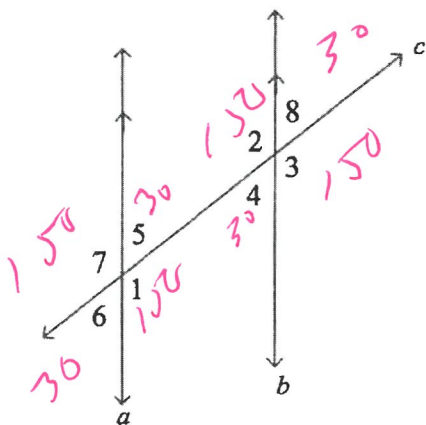

Which statements are true? Select all that apply.

- $\angle 6$ and $\angle 7$ are vertical angles that each measure 30° .
- $\angle 5$ and $\angle 6$ are vertical angles that each measure 30° .
- $\angle 4$ and $\angle 6$ are corresponding angles that each measure 30° .
- $\angle 4$ and $\angle 7$ are corresponding angles that each measure 150° .
- $\angle 3$ and $\angle 5$ are alternate interior angles that each measure 150° .
- $\angle 3$ and $\angle 7$ are alternate exterior angles that each measure 150° .
- $\angle 1$ and $\angle 4$ are consecutive interior angles that measure 30° and 150° , respectively.

? NO two put yes!

16. Two lines are cut by a transversal. The measures of a pair of consecutive interior angles are $(5x + 20)^\circ$ and $(x + 40)^\circ$. What is the value of x that makes the two lines parallel?

$x = 20^\circ$

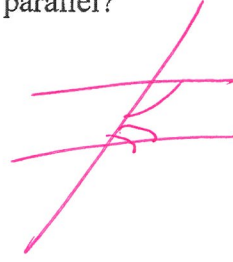

$6x + 60 = 180$

$6x = 120$

$x = 20$

17. Consider the figure below.

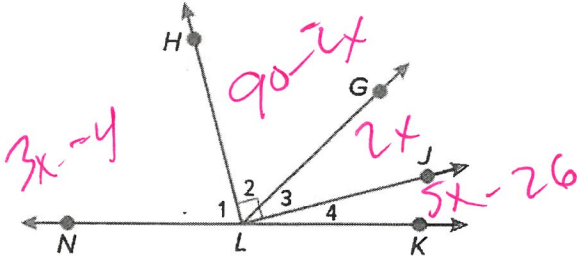

If $m\angle NLH = (3x - 4)^\circ$, $m\angle JLK = (5x - 26)^\circ$, and $m\angle GLJ = 2x^\circ$, find $m\angle HLG$.

- $m\angle HLG =$ Circle One: 15° 30° 41° 60° 49° 90° 120°

$8x + 60 = 180$

$8x = 120$

$x = 15$

$90 - 2(15)$

1. James and Mateo are building a set for a play and have to nail boards together into congruent triangles. James says they just have to check that all pairs of corresponding angles in the triangles are congruent. Mateo says they need to check that at least one pair of corresponding sides is congruent too.

Which statements are true? Select all that apply.

- Mateo is correct due to the AAS congruence criterion.
- Mateo is correct due to the SSS congruence criterion.
- Mateo is correct due to the ASA congruence criterion.
- James is correct due to the AAS congruence criterion.
- James is correct due to the AA congruence criterion.

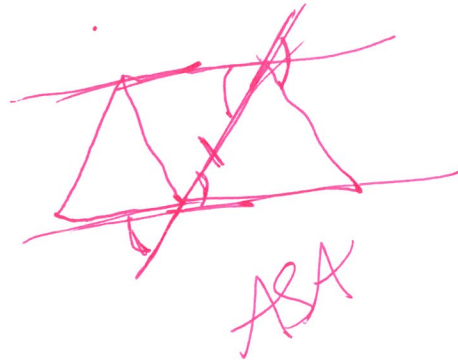

2. In the figure below, $\triangle ABC \cong \triangle PQR$.

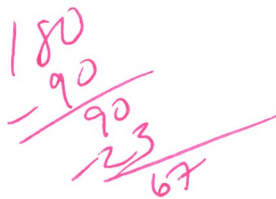
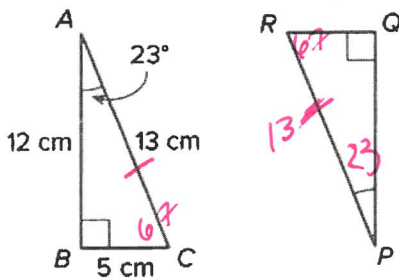

- The measure of $\angle QPR$ is $(23^\circ, 67^\circ, 90^\circ)$, and the length of \overline{PR} is $(5, 12, 13)$ cm.

3. Quadrilaterals $ABCD$ and $QRST$ are congruent.

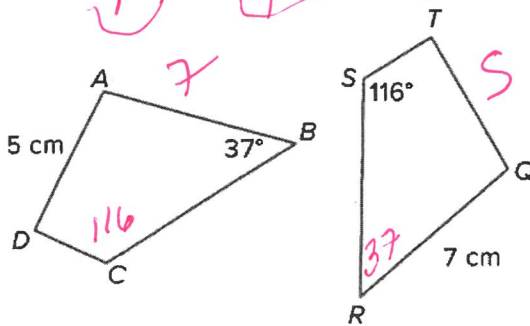

Which statements are true? Select all that apply.

- $m\angle R = 27^\circ$
- $m\angle R = 37^\circ$
- $m\angle D = 116^\circ$
- $QT = 7$ cm
- $AB = 5$ cm
- $AB = 7$ cm

21 4. Consider $\triangle ABC$ and $\triangle DEF$ below.

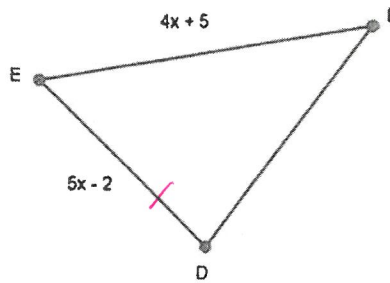
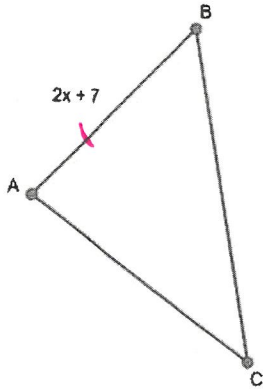

$4(3) + 5$

$2x + 7 = 5x - 2$
 $9 = 3x$
 $x = 3$

Part A: Determine the value of x that makes $\triangle ABC \cong \triangle DEF$.

• $x = \underline{3}$

Part B: Find EF .

• $EF = \underline{17}$

22 5. Find the values of x and y if $\triangle PQS \cong \triangle RQS$.

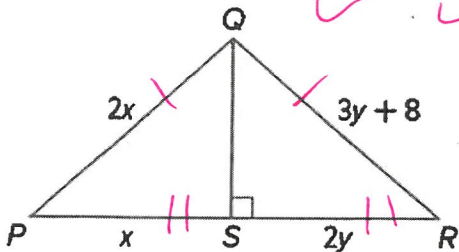

$2x = 3y + 8$
 $x = 2y$
 $2(2y) = 3y + 8$
 $4y = 3y + 8$
 $y = 8$
 $x = 2(8)$

• $x = \underline{16}$

• $y = \underline{8}$

1. Consider the polygons shown, where $ABCDE \sim A'B'C'D'E'$.

If $DC = 2x + 1$, $D'C' = 9$, $BC = 1$, and $B'C' = 3$, find the value of x .

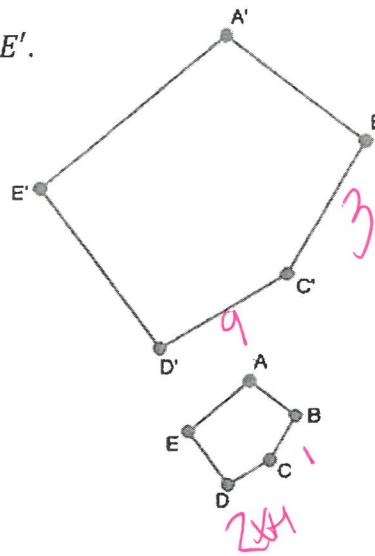

$x = 1$

2. Consider the figure below, where $\triangle ADE \sim \triangle ABC$,

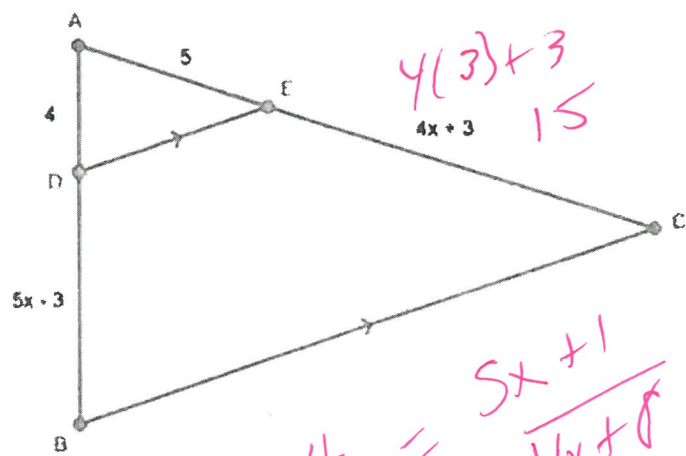

$$\frac{1}{3} = \frac{2x+1}{9}$$

$$9 = 6x + 3$$

$$6 = 6x$$

$$1 = x$$

$$4(3) + 3 = 15$$

$$4x + 3 = 15$$

$$\frac{4}{5} = \frac{5x+1}{4x+3}$$

$$25x + 5 = 16x + 32$$

$$9x = 27$$

$$x = 3$$

Part A: Find the value of x .

- A. 2
- B. 3
- C. 4
- D. 5

Part B: Find the length of \overline{AC} .

- A. 3
- B. 12
- C. 15
- D. 19
- E. 20

25. Your family decides to put a rectangular patio in your backyard, similar to the shape of your backyard. Your backyard has a length of 63 feet and a width of 36 feet. The length of your new patio is 14 feet. Find the width of your new patio.

- The width of the new patio is 8 feet.

$$\frac{63}{14} = \frac{36}{x}$$

$$x = 8$$

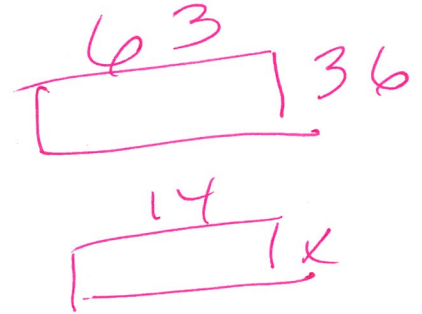

26. A flagpole casts a shadow that is 180 feet long. At the same time, a person standing nearby who is 5 feet tall casts a shadow that is 60 feet long. How tall is the flagpole?

- A. 13 ft
- B. 14 ft
- C. 15 ft
- D. 16 ft



$$\frac{x}{180} = \frac{5}{60}$$

27. Mario is making a toy sailboat with the dimensions shown. Find the height of the mast to the nearest tenth of a centimeter.

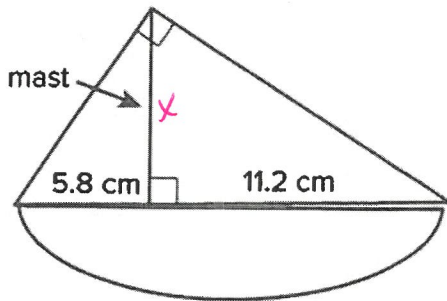

$$x^2 = 5.8(11.2)$$

- The height of the mast is (3.0 , 6.7 , 8.1 , 9.6 , 12.6 , 21.6) cm.

6. Luisa is putting up a flagpole and needs to know the length of the support cables. The bases of the cables will be 6 feet and 10 feet away from the base of the flagpole. Find the lengths of the cables and the flagpole to the nearest tenth of a foot.

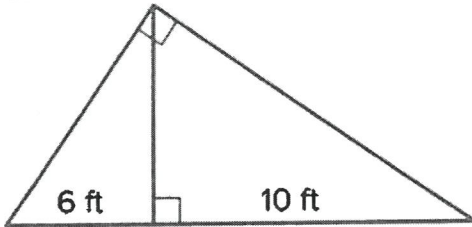

- The length of the flagpole is 7.7 feet.
- The length of the longer cable is 12.6 feet.
- The length of the shorter cable is 9.8 feet.

20. Consider the given preimage and image below.

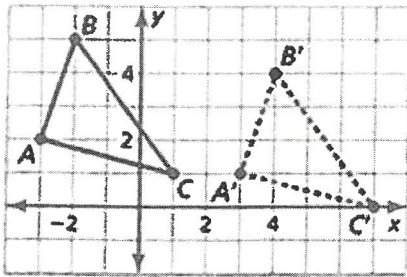

- Does $AB = A'B'$? (yes, no)

21. Consider the given preimage and image below.

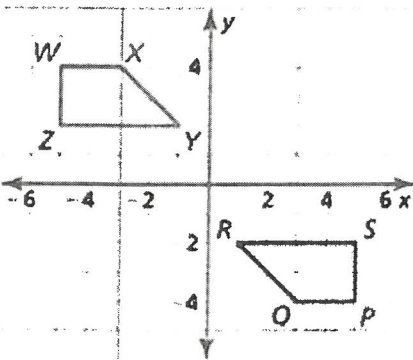

- Does the transformation above preserve distance? (yes, no)

Residual Motion

313. Which of the following transformations does not preserve distance?

- A. Horizontal translation
- B. Dilation
- C. Reflection in the line $y = x$
- D. Counterclockwise rotation of 180° around the origin

324. Which of the following transformations do not preserve distance?

- A. $(x, y) \rightarrow (-y, x)$ *90° CCW*
- B. $(x, y) \rightarrow (x + 3, y - 1)$
- C. $(x, y) \rightarrow (-x, -y)$ *180° rotation*
- D. $(x, y) \rightarrow (2x, 2y)$ *dilation*

- 33 5. Determine whether the given transformation preserve distance and/or angle measure.

Transformation	Preserves Distance?	Preserves Angle Measure?
1. $(x, y) \rightarrow (y, x)$	(yes, no)	(yes, no)
2. Dilation with a scale factor of $\frac{1}{3}$	(yes, no)	(yes, no)
3. Translation 4 up and 2 down	(yes, no)	(yes, no)
4. $(x, y) \rightarrow (y, -x)$ 270° C CW	(yes, no)	(yes, no)
5. Rotation clockwise of 270° about the origin $-y, x$	(yes, no)	(yes, no)
6. $(x, y) \rightarrow (y, -2x)$	(yes, no)	(yes, no)
7. Dilation with a scale factor of 5	(yes, no)	(yes, no)

34) Consider $\triangle ABC$ inscribed in the circle below.

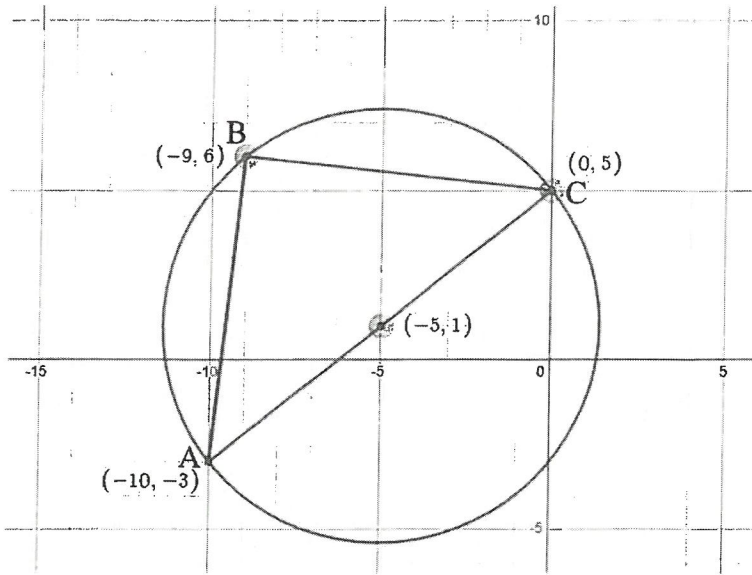

Which of the following justifies Thales' Theorem (if points A , B , and C lie on a circle such that \overline{AC} is a diameter, then $m\angle ABC = 90^\circ$)?

- A. $\overline{AB} = \overline{BC} = \sqrt{82}$
- B. $\overline{AB} = \overline{BC} = \sqrt{5}$
- C. The slope of $\overline{AB} = 9$, the slope of $\overline{BC} = -\frac{1}{9}$, and $9 \cdot -\frac{1}{9} = -1$
- D. The slope of $\overline{AB} =$ the slope of $\overline{BC} = 9$

352. Consider the circle below and one of its tangent lines.

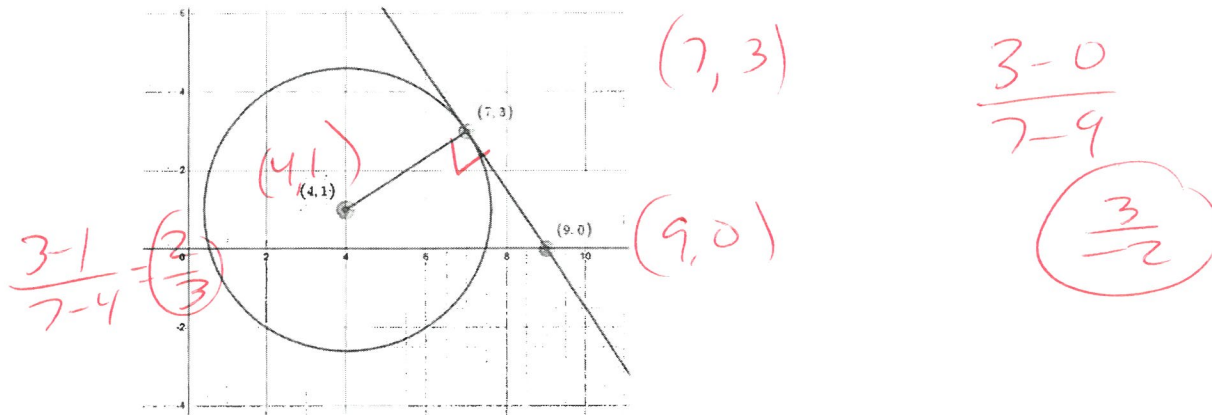

Complete the sentence below which justifies the theorem that a line tangent to a circle is perpendicular to the radius at the point of tangency.

The slope of the tangent line is $(-\frac{3}{2}, -\frac{2}{3}, \frac{2}{3}, \frac{3}{2})$ and the slope of the radius is $(-\frac{3}{2}, -\frac{2}{3}, \frac{2}{3}, \frac{3}{2})$.

Because the slopes (are equal, are opposite reciprocals, are reciprocals) the radius is (parallel, perpendicular) to the tangent line.

16. Consider the circle below with chord \overline{CD} .

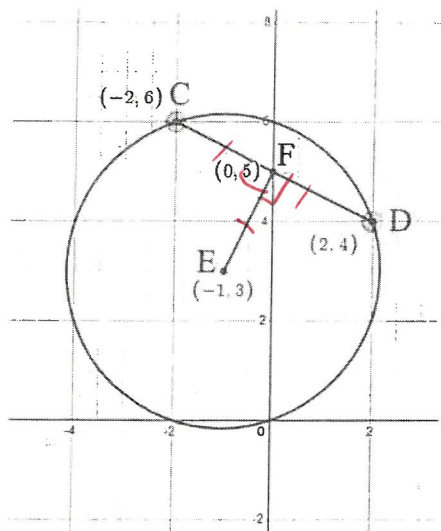

Part A: In order to prove that E is the center of the circle we must show that:

Select all that apply.

- $\overline{CD} \perp \overline{EF}$
- $\overline{CD} \parallel \overline{EF}$
- $\overline{CD} \cong \overline{EF}$
- $\overline{CF} \cong \overline{FD}$

Part B: Find the following measurements. Write exact answers.

- The slope of \overline{CD} is $-\frac{1}{2}$. $\frac{6-4}{-2-2} = -\frac{2}{4}$
- The slope of \overline{EF} is $\frac{2}{1}$. $\frac{5-3}{0-(-1)} = \frac{2}{1}$
- $CF = \sqrt{5}$. $\sqrt{(-2-0)^2 + (6-5)^2} = \sqrt{2^2 + 1^2} = \sqrt{4+1} = \sqrt{5}$
- $FD = \sqrt{5}$. $\sqrt{(0-2)^2 + (5-4)^2} = \sqrt{2^2 + 1^2} = \sqrt{4+1} = \sqrt{5}$
- $CD = \sqrt{5} + \sqrt{5} = 2\sqrt{5}$
- $EF = \sqrt{5}$. $\sqrt{(0-(-1))^2 + (5-3)^2} = \sqrt{1^2 + 2^2} = \sqrt{1+4} = \sqrt{5}$

Part C: Is E the center of the circle? (yes, no)

31

4. Consider the circle (centered at the origin) below. Points A and B lie on the x -axis.

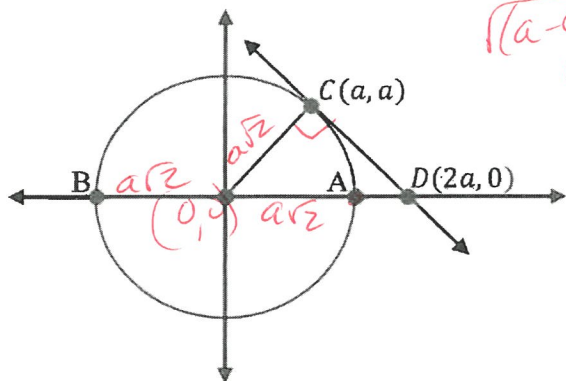

$\frac{1}{\sqrt{2}}$
 $\frac{1}{\sqrt{2}}$
 $\frac{1}{\sqrt{2}}$

Part A: Find the length of the radius as an exact answer. $a\sqrt{2}$

Part B: Find the coordinates of points A and B .

- $A(\underline{a\sqrt{2}}, \underline{0})$
- $B(\underline{-a\sqrt{2}}, \underline{0})$

Part C: Find the following measurements. Use exact answers.

- $DB = \underline{(2a - a\sqrt{2}) + a\sqrt{2} + a\sqrt{2} = 2a + a\sqrt{2}}$
- $DA = \underline{2a - a\sqrt{2}}$
- $CD = \underline{a\sqrt{2}}$

Part D: Use your answers in Part C to prove the secant tangent length theorem ($CD^2 = DB \cdot DA$)

$$CD^2 = (2a + a\sqrt{2})(2a - a\sqrt{2})$$

$$= 4a^2 - 2a^2 = 2a^2$$

58. Classify the triangle below.

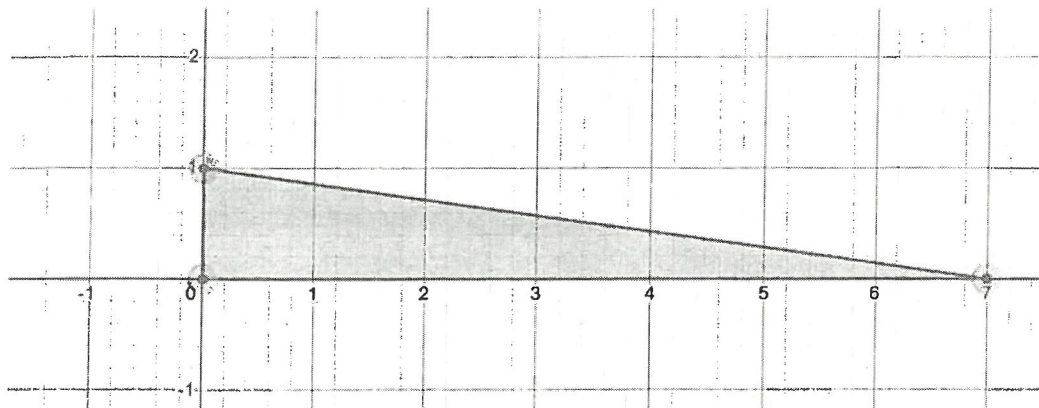

- The triangle above is a(n) (acute, obtuse, right) (scalene, equilateral, isosceles).

59. Consider $\triangle JKL$ with vertices $J(0, 1)$, $K(7, 0)$, and $L(5, 6)$.

Part A: Draw the triangle in the coordinate plane below.

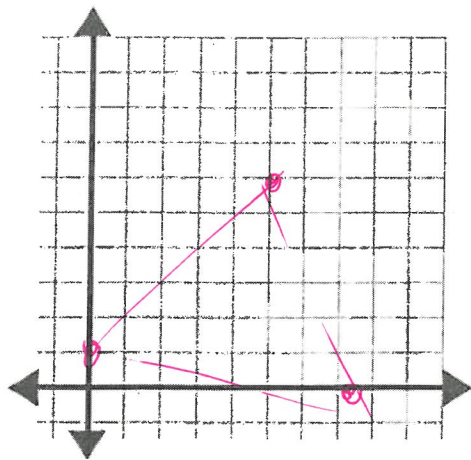

Use distance formula to prove

Part B: Complete the sentence to classify $\triangle JKL$.

- The triangle above is a(n) (acute, obtuse, right) (scalene, equilateral, isosceles).

30 3. Triangle ABC has vertices $A(1,1)$, $B(3,2)$, and $C(0,3)$. Which of these options correctly justifies the claim that the triangle is an isosceles right triangle? *Graph*

- A. The claim is correct b/c the slope of \overline{AB} is -2 , which is the reciprocal of \overline{AC} , and $AB = AC = \sqrt{10}$.
- B. The claim is correct b/c the slope of \overline{AB} is -2 , which is the reciprocal of \overline{AC} , and $AB = AC = \sqrt{5}$.
- C. The claim is correct b/c the slope of \overline{AB} is $\frac{1}{2}$, which is the opposite reciprocal of \overline{AC} , and $AB = AC = \sqrt{10}$.
- D. The claim is correct b/c the slope of \overline{AB} is $\frac{1}{2}$, which is the opposite reciprocal of \overline{AC} , and $AB = AC = \sqrt{5}$.

41 4. Consider $\triangle DEF$ has vertices $D(0,0)$, $E(7,3)$, and $F(3,5)$. *graph*

Part A: Classify the triangle by side length and write the length using an exact answer.

- $\triangle DEF$ is a(n) (scalene, equilateral, isosceles) triangle.

• $\overline{DE} = \underline{\sqrt{58}}$

• $\overline{EF} = \underline{2\sqrt{5}}$

• $\overline{DF} = \underline{\sqrt{34}}$

Use distance formula to prove

Part B: Classify the triangle by angle measure.

- $\triangle DEF$ is a(n) (acute, obtuse, right) triangle because ($a^2 + b^2 < c^2$, $a^2 + b^2 = c^2$, $a^2 + b^2 > c^2$)

$c^2 > a^2 + b^2$
 $\sqrt{58}^2 > (2\sqrt{5})^2 + (\sqrt{34})^2$

$58 > 4 \cdot 5 + 34$

$58 > 20 + 34$

$58 > 54$

5. Clarkesville's flying disc championship is held annually at the county soccer fields. Contestants sling a flying disc to a target located 30 yards west and 60 yards north of the starting point. The next target is 30 yards east and 30 yards north of the starting point. The final target is back at the starting point. Use coordinate geometry to determine the type of triangle formed by the starting point and targets.

Part A: Classify the triangle by side length and write the length using an exact answer.

- The triangle is a(n) (scalene , equilateral , isosceles) triangle.

- The smallest side, a , is $30\sqrt{2}$

- The middle side, b , $30\sqrt{5}$

- The largest side, c , is $30\sqrt{5}$

Use distance formula to prove

Part B: Classify the triangle by angle measure.

- The triangle is a(n) acute (acute, obtuse, right) triangle b/c ($a^2 + b^2 < c^2$, $a^2 + b^2 = c^2$, $a^2 + b^2 > c^2$)

$$c^2 < a^2 + b^2$$

3. Consider the quadrilateral drawn below.

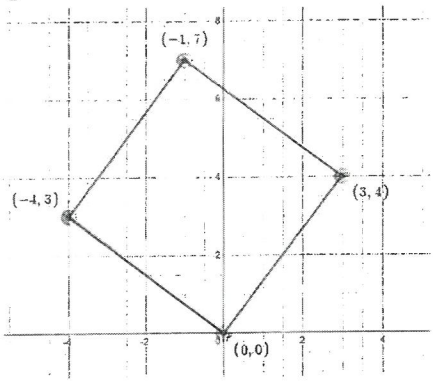

Which of the following best classifies the quadrilateral?

- A. Trapezoid
- B. Parallelogram
- C. Rectangle
- D. Rhombus
- E. Square

4. Consider the quadrilateral drawn below.

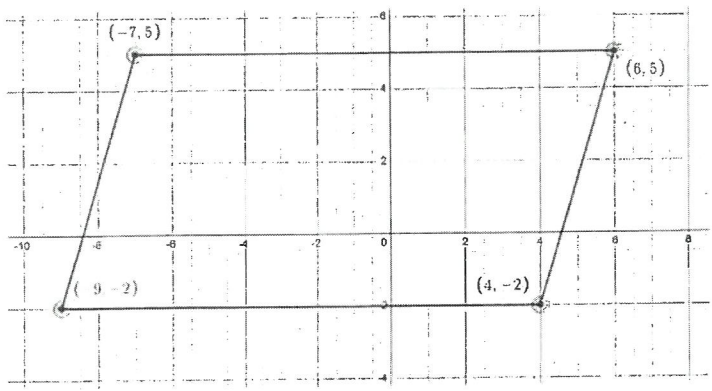

Classify the quadrilateral. Select all that apply.

- Trapezoid
- Parallelogram
- Rectangle
- Rhombus
- Square

45. Consider quadrilateral $ABCD$ with vertices $A(-3, 1)$, $B(4, 2)$, $C(9, -3)$, and $D(2, -4)$.

Part A: Draw the quadrilateral in the coordinate plane below.

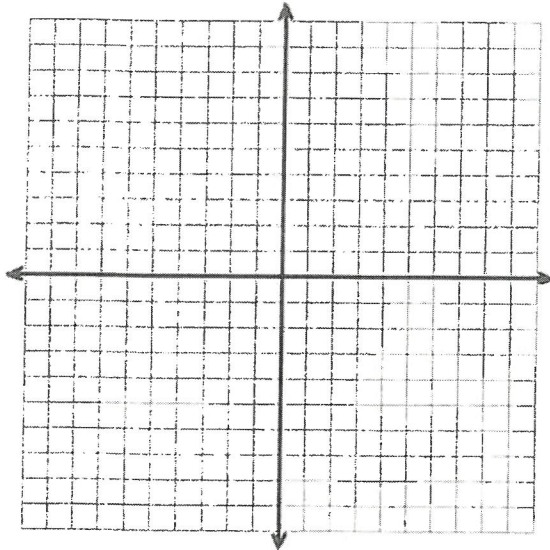

Part B: Complete the statement below to best classify $ABCD$.

In $ABCD$, (only opposite sides , all of the sides) have equal length and there are (no , four) right angles, so $ABCD$ is best classified as a (rectangle , rhombus , square , parallelogram).

46. Parallelogram $EFGH$ has vertices $E(-1,4)$, $F(3,-2)$, and $G(4,6)$. What are the coordinates of point H ?

• $H(0, 12)$

yes

graph

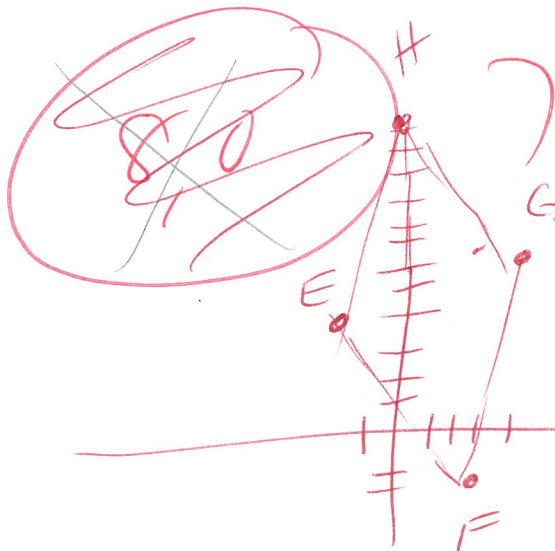

17. Consider the following problem:

Quadrilateral $JKLM$ has vertices $J(-1,3)$, $K(2,0)$, $L(-1,-6)$, and $M(-4,-3)$. Determine whether each statement about quadrilateral $JKLM$ is true or false. **GRAPH**

	True	False
The quadrilateral is a parallelogram.	X	
The quadrilateral is a rectangle.		X
Both pairs of opposite sides are congruent.	X	
The diagonals bisect each other.		X
One pair of opposite sides are parallel.		X
Both pairs of opposite sides are parallel.	X	
At least one pair of opposite sides are both parallel and congruent.	X	

If the X's represent a student's answer and below is their work shown, which of the following explain the student's error (if any)?

Sides:

① $J(-1,3)$, $K(2,0)$ ② $L(-1,-6)$, $M(-4,-3)$

$m = \frac{0-3}{2+1} = -1$ $m = \frac{-3+6}{-4+1} = -1$

$d = \sqrt{(2+1)^2 + (0-3)^2} = \sqrt{3^2 + (-3)^2} = \sqrt{9+9} = \sqrt{18} = 3\sqrt{2}$ $d = \sqrt{(-4+1)^2 + (-3+6)^2} = \sqrt{(-3)^2 + 3^2} = \sqrt{9+9} = \sqrt{18} = 3\sqrt{2}$

③ $J(-1,3)$, $M(-4,-3)$ ④ $L(-1,-6)$, $K(2,0)$

$m = \frac{-3-3}{-4+1} = -2$ $m = \frac{0+6}{2+1} = 2$

$d = \sqrt{(-4+1)^2 + (-3-3)^2} = \sqrt{(-3)^2 + (-6)^2} = \sqrt{9+36} = \sqrt{45} = 3\sqrt{5}$ $d = \sqrt{(2+1)^2 + (0+6)^2} = \sqrt{3^2 + 6^2} = \sqrt{9+36} = \sqrt{45} = 3\sqrt{5}$

* opposite sides \parallel & \cong !

* slopes NOT \perp !

Diagonals:

⑤ $J(-1,3)$, $L(-1,-6)$ ⑥ $M(-4,-3)$, $K(2,0)$

$m = \frac{-6-3}{-1+1} = 0 = \text{undef}$ $m = \frac{0-3}{2+4} = -\frac{1}{6} = -\frac{1}{6}$

* diagonals not \perp , not bisectors!

- A. There is no error in the student's answer.
- B. The quadrilateral is a rectangle because the adjacent sides have perpendicular slopes.
- C. The student found that the diagonals are not perpendicular, not that they do not bisect each other.
- D. The student found that adjacent sides are congruent, not opposite sides.

distance
 $\sqrt{(8-4)^2 + (5+2)^2}$
 $4^2 + 7^2 = 16 + 49$
 $r = \sqrt{65}$

8) A circle with center $(4, -2)$ passes through the point $(8, 5)$. **Graph**

Which are coordinates of another point on the circle? **Select all that apply.**

- $(-3, 2)$
- $(-2, 4)$
- $(0, -9)$
- $(0, 5)$
- $(11, -6)$

$(x-4)^2 + (y+2)^2 = 65$

graph to / or play in!

9) Lacey is designing a park with a circular fountain and a path that runs in a straight-line tangent to it.

What is the equation of the line?

- A. $y = -\frac{3}{2}x + \frac{41}{2}$
- B. $y = -\frac{3}{2}x + 14$
- C. $y = -\frac{2}{3}x + 13$
- D. $y = \frac{2}{3}x + 1$

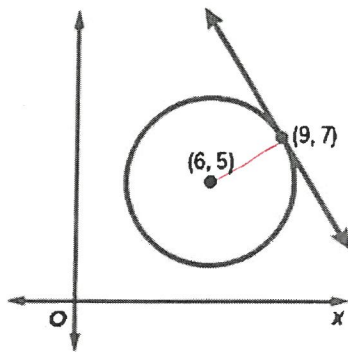

$y = mx + b$

slope
 $\frac{7-5}{9-6} = \frac{2}{3}$

neg. recip
 $-\frac{3}{2}$

$y = mx + b$

$7 = -\frac{3}{2}(9) + b$
 $7 = -\frac{27}{2} + b$
 $7 + \frac{27}{2} = b$
 $\frac{14}{2} + \frac{27}{2} = b$
 $\frac{41}{2} = b$

10) Circle K has its center at $(2, -3)$, with a tangent line with equation $x = 0$. Write the equation of a line tangent to the circle and perpendicular to $x = 0$. Select all that apply. **Graph**

- $x = -5$
- $x = -1$
- $x = 1$
- $x = 5$
- $y = -5$
- $y = -1$
- $y = 1$
- $y = 5$

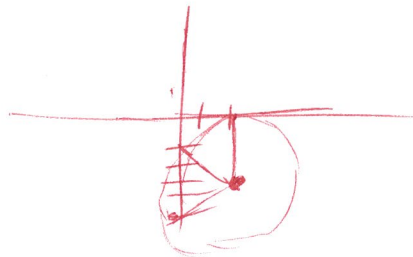

51) 4. Line l has the equation $x - 3y = -15$ and is tangent to $\odot C$ whose center is located at $(1, 2)$.

Graph

Which statements are true? Select all that apply.

$$\begin{array}{r} x - 3y = -15 \\ -x \qquad \qquad -x \\ \hline -3y = -x - 15 \\ \div -3 \\ \hline y = \frac{1}{3}x + 5 \end{array}$$

- The point of tangency of line l to $\odot C$ is $(0, 5)$.
- The point of tangency of line l to $\odot C$ is $(-1, 8)$.
- The line $y = \frac{1}{3}x + \frac{5}{3}$ is also tangent to $\odot C$.
- The line $y = \frac{1}{3}x - \frac{5}{3}$ is also tangent to $\odot C$.
- The line $y = -3x + 5$ contains the diameter of $\odot C$ that intersects line l at the point of tangency.
- The line $y = 3x + 5$ contains the diameter of $\odot C$ that intersects line l at the point of tangency.

52) 5. Circle A is centered at $(2, 2)$ and contains point $P(4, 4)$.

Graph

Part A: Write the equation of the line, in slope-intercept form, containing the radius to point P .

$$y = x$$

Part B: Write the equation of a line, in slope-intercept form, tangent to $\odot A$ at P .

$$y = -x + 8$$

Part C: What property of tangent lines can we prove using your answers to Parts A & B?

- A. Two tangent lines drawn from the same exterior point are congruent.
- B. A tangent line is always perpendicular to the radius drawn from the point of tangency.
- C. The angle formed by the intersection of two tangent lines is half the measure of its corresponding arc.
- D. The measure of a radius is half the measure of its tangent line.

Part D: Write the equation of a line tangent to $\odot A$ and vertical.

$$x = 2 \pm 2\sqrt{2}$$

Part E: Write the equation of a line tangent to $\odot A$ and horizontal.

$$y = 2 \pm 2\sqrt{2}$$

3) 1. Consider the points $A(-4, -1)$ and $B(3, -3)$. Find the length of AB . Select all that apply.

- 7.28
- 6.71
- $\sqrt{53}$
- $\sqrt{17}$
- $\sqrt{45}$
- $3\sqrt{5}$

4) 2. Write the equation of the line, in slope-intercept form, that is parallel to $y = 3x + 1$ and passes through the point $(-2, 3)$

Graph

- $y = (-3, -\frac{1}{3}, \frac{1}{3}, 3)x (+, -) (0, 1, 2, 3, 4, 5, 6, 7, 8, 9, 10)$

$$y = 3x + 9$$

$$y = mx + b$$

$$3 = 3(-2) + b$$

$$3 = -6 + b$$

$$9 = b$$

5) 3. Given $J(-4, 2)$ and $K(2, 1)$, find the coordinates of point M on \overline{JK} that partitions the line segment in the ratio 1:2.

A. $(0, \frac{4}{3})$

B. $(-1, \frac{3}{2})$

C. $(-2, \frac{5}{3})$

D. $(-2, 3)$

$\frac{-4}{1} \frac{2}{2}$	$\frac{2}{1} \frac{1}{2}$
$\frac{2-8}{3}$	$\frac{1+4}{3}$
$\frac{-6}{3}$	$(\frac{5}{3})$

6) 4. Point M is the midpoint of \overline{AB} . Find the coordinates of point B .

Graph

- $A(4, -1)$
- $M(1, 5)$

○ Point B is located at $(\underline{-2}, \underline{11})$

$$\frac{4+x}{2} = 1$$

$$4+x = 2$$

$$x = -2 - 3 | -$$

$$\frac{-1+y}{2} = 5$$

$$-1+y = 10$$

$$y = 11$$

1. One diagonal of a rectangle has the endpoints of $(-3, 6)$ and $(5, -6)$. Which are the coordinates of another vertex of the rectangle? Select all that apply. **Graph**

- $(-5, -6)$
- $(-3, -6)$
- $(5, 6)$
- $(3, 6)$
- $(-5, 6)$
- $(3, -6)$

2. Two of the vertices of rectangle $RSTU$ are $R(1, 4)$ and $S(2, 1)$. The rectangle has a side of length $\sqrt{40}$ and is contained in the first quadrant. **GRAPH**

Which statements are true? Select all that apply.

- $(4, 5)$ is a vertex of $RSTU$.
- $(7, 6)$ is a vertex of $RSTU$.
- $y = -3x + 7$ contains a side of $RSTU$.
- $y = 3x + 1$ contains a side of $RSTU$.
- $y = \frac{1}{3}x + \frac{11}{3}$ contains a side of $RSTU$.
- $y = -\frac{1}{3}x + \frac{5}{3}$ contains a side of $RSTU$.

3. The lines $y = -x + 4$ and $y = 2x - 2$ and their intersection contain two sides of a parallelogram. One vertex is $(6, 4)$. Complete the sentences to find the equations of the lines containing the other sides of the parallelogram. **GRAPH**

One line containing a side of the parallelogram is (parallel, perpendicular) to $y = -x + 4$ and passes through the point $(6, 4)$. Its equation is $y = (-0.5, -1, 1, 2)(x - 6) + 4$.

The other line has the equation $y = (-2, -0.5, 0.5, 2)x + (-8, -2, 4, 6)$.

$$y = -1(x - 6) + 4$$

$$= -1x + 6 + 4$$

$$y = -1x + 10$$

see graph

60. Consider the Trapezoid $JKLM$ that is graphed on a coordinate plane below.

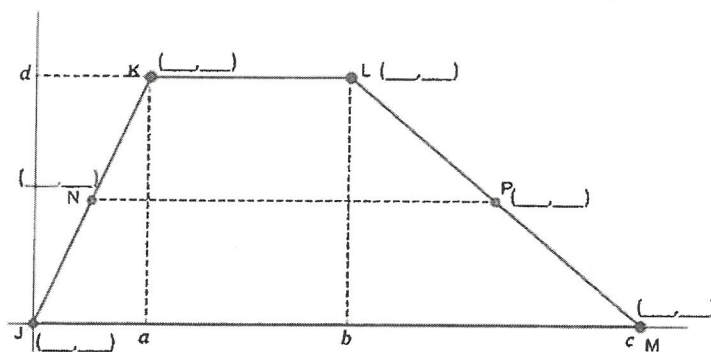

Part A: Write the coordinates of $J, K, L,$ and M .

- $J(\underline{0} , \underline{0})$
- $K(\underline{a} , \underline{d})$
- $L(\underline{b} , \underline{d})$
- $M(\underline{c} , \underline{0})$

Part B: If N is the midpoint of \overline{JK} and P is the midpoint of \overline{LM} . What are the coordinates of points N and P ?

- $N(\underline{\frac{a}{2}} , \underline{\frac{d}{2}})$
- $P(\underline{\frac{b+c}{2}} , \underline{\frac{d}{2}})$

Part C: Find the lengths of $KL, NP,$ & JM .

- $KL = \underline{\frac{b-a}{1}}$
- $NP = \underline{\frac{b+c-a}{2}}$
- $JM = \underline{c}$

Part D: Use your answers to Part C to prove the Trapezoid Midsegment Theorem. Show all work.

$$\cancel{JK} \quad \frac{KL + JM}{2} = NP$$

1) 1. Consider $\triangle ABC$ with vertices $A(4, -1)$, $B(-2, 3)$, and $C(6, 11)$. Find the midpoints of each side.

- \overline{AB} has a midpoint at (1, 1)
- \overline{BC} has a midpoint at (2, 7)
- \overline{AC} has a midpoint at (5, 5)

GRAPH

2) 2. Consider $\triangle DEF$ with vertices $D(1, 3)$, $E(-1, 8)$, and $F(7, 6)$. What is the equation of the line containing the median that passes through D ?

- $y =$ 2 $x +$ 1

GRAPH

3) 3. Consider $\triangle FSU$ with a vertex at $F(0, 0)$. If the median that passes through F , intersects side \overline{SU} at $(3, 9)$, find the centroid of $\triangle FSU$.

- The centroid of $\triangle FSU$ is located at (2, 6)

GRAPH

4) 4. Consider $\triangle FAU$ with a vertex at $F(2, -1)$ and $A(6, 3)$. Which of the following could be coordinates of the third vertex, if $\triangle FAU$ is a right triangle, with the right angle at A ?

- A. (1, 0)
- B. (3, 2)
- C. (5, 0)
- D. (4, 5)

GRAPH

5) 5. Given $\triangle KIM$ with vertices at $K(2, -3)$, $I(-8, -3)$, and $M(-12, -8)$, what are the coordinates for the centroid of the triangle?

- A. $(-9, -7)$
- B. $(-6, -\frac{14}{3})$
- C. $(-9, -\frac{19}{3})$
- D. $(-\frac{15}{2}, -\frac{11}{2})$

find average

$$2 + -8 + -12$$

$$\frac{\quad}{3}$$

$$-6$$

$$-34$$

GRAPH

$$-3 + -3 + -8$$

$$\frac{\quad}{3}$$

$$-14$$

$$\frac{\quad}{3}$$

6) Consider $\odot P$ shown below. Highlight $\angle BPA$, include both rays and mark the interior with an arc mark.

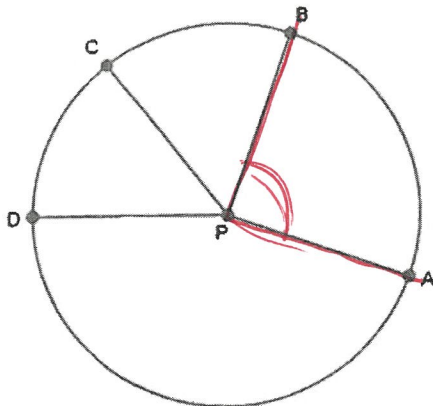

7) Given $\odot P$, $m\angle CPA = 135^\circ$, and $m\widehat{DA} = 162^\circ$, find $m\widehat{CD}$.

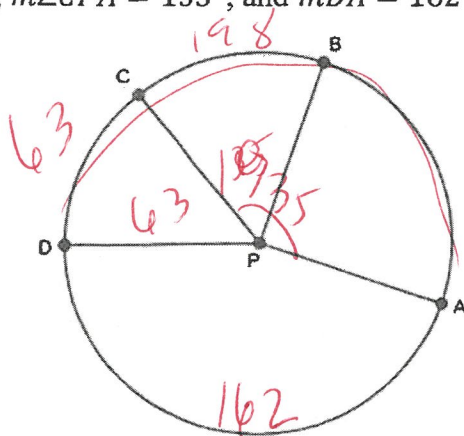

$$\begin{array}{r} 360 \\ -102 \\ \hline 198 \\ -135 \\ \hline 63 \end{array}$$

• $m\widehat{CD} = \underline{63}^\circ$

8) Given $\odot T$, if $m\angle PTJ = (3x - 2)^\circ$, find the value of x .

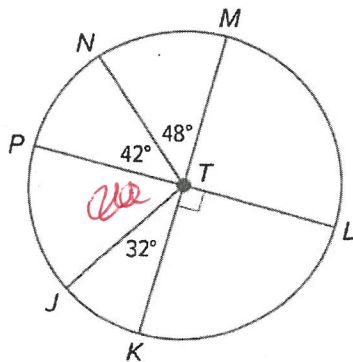

$$\begin{array}{r} 180 \\ -48 \\ -42 \\ -32 \\ \hline 58 \end{array}$$

$$\begin{array}{r} 3x - 2 = 58 \\ +2 \quad +2 \\ \hline 3x = 60 \\ \hline x = 20 \end{array}$$

• $x = \underline{(20, 30, 45, 58, 90)}^\circ$

69

4. The high school prom committee surveyed students to find out which theme would be most popular for the upcoming prom. The circle graph shows the result of the survey. Find $m\widehat{AB}$.

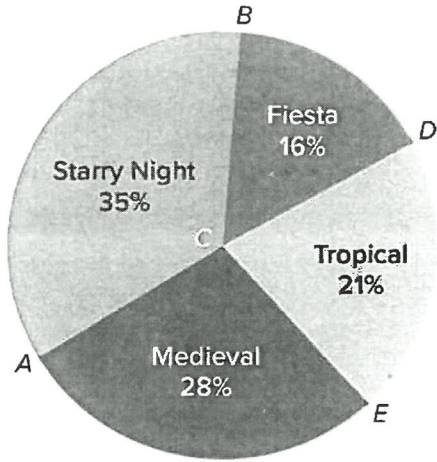

$$\frac{35}{100} = \frac{x}{360}$$

• $m\widehat{AB} = \underline{126}^\circ$

$$\frac{360(35)}{100} = \frac{100x}{100}$$

$$126 = x$$

10. Consider $\odot B$ shown below. Highlight the arc(s) whose measure are needed to find $m\angle 2$.

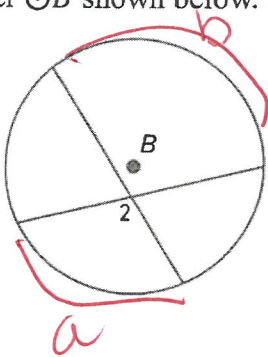

$$\frac{a+b}{2} = \angle 2$$

11. Consider the circle given below. Find $m\widehat{UW}$.

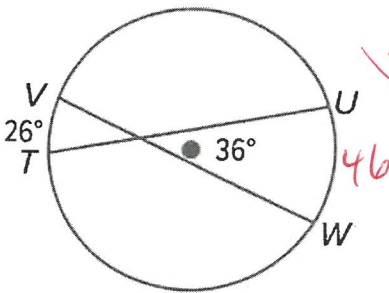

• $m\widehat{UW} = \underline{46}^\circ$

~~$\frac{26+x}{2} = 36$~~
 ~~$26+x = 72$~~
 ~~$\frac{26+x = 36}{2}$~~ $\frac{26+x = 72}{-26} \quad \frac{-26}{-26}$
 $x = 46$

12. In the figure below, $m\widehat{VW} = (3x + 40)^\circ$, $m\widehat{XY} = (10x + 16)^\circ$, and $m\angle YZX = 54^\circ$. Find the value of x .

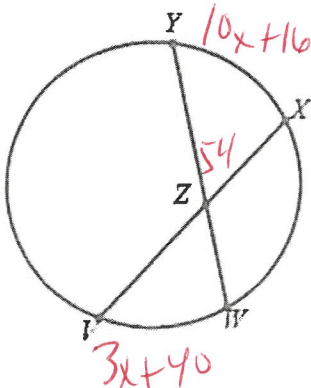

• $x = \underline{4}^\circ$

$$\frac{10x+16 + 3x+40}{2} = 54$$

$$\frac{13x+56}{2} = 54$$

$$13x+56 = 108$$

$$\frac{13x}{13} = \frac{52}{13}$$

$$x = 4$$

13. Find the value of x .

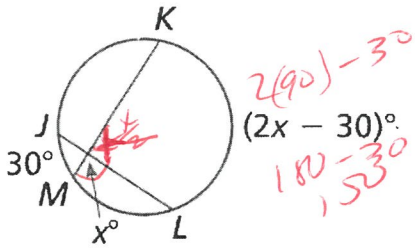

• $x = \underline{90}^\circ$

$$\frac{30 + 2x + 30}{2}$$

$$\frac{150 + 30}{2} = \frac{180}{2} = 90$$

14. Find the value of x .

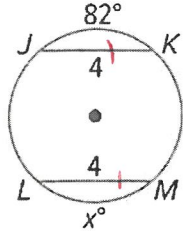

• $x = \underline{82}^\circ$

15. Find the value of x .

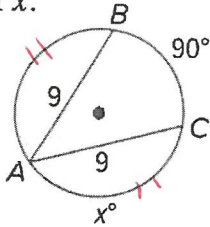

$$\frac{360 - 90}{2} = 135$$

• $x = \underline{135}^\circ$

16. In $\odot A$, $m\widehat{CD} = 90^\circ$. Find $m\widehat{DE}$.

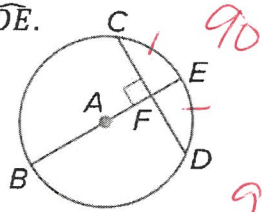

$90/2 = 45$

• $m\widehat{DE} = \underline{45}^\circ$

17. A circular garden has paths around its edge that are identified by the given arc measures. It also has four straight paths, identified by segments \overline{AC} , \overline{AD} , \overline{BE} , and \overline{DE} , that cut through the garden's interior. Which two straight paths have the same length?

- A. \overline{AC}
- B. \overline{AD}
- C. \overline{BE}
- D. \overline{DE}

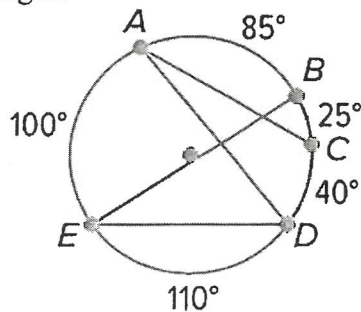

1. Consider $\odot O$ shown below.

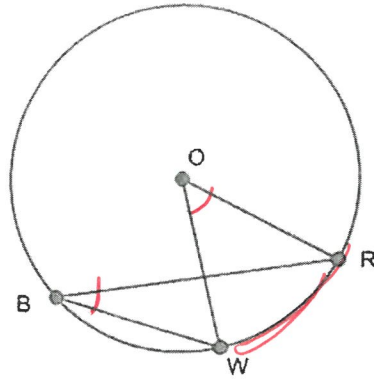

Part A: With one color, highlight $\angle WBR$, include both rays and mark the interior with an arc mark.

Part B: With another color, mark the intercepted arc of $\angle WBR$.

Part C: Name the arc you highlighted in Part B. WR

2. Consider $\odot O$ shown below. If $m\angle ROW = 30^\circ$, find $m\angle WBR$.

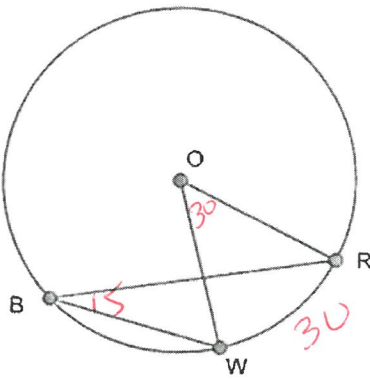

- $m\angle WBR = (10, 15, 20, 30, 45, 60)^\circ$

20

Progressive Problems

3. Consider the circle given below.

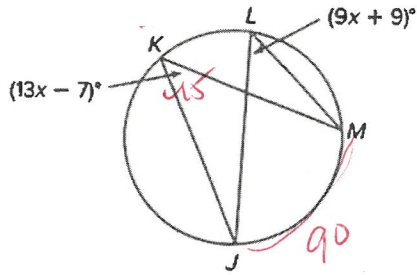

$$\begin{array}{r}
 13x - 7 = 9x + 9 \\
 + 7 \quad + 7 \\
 \hline
 13x = 9x + 16 \\
 - 9x \quad - 9x \\
 \hline
 4x = 16 \\
 x = 4
 \end{array}$$

Part A: Find the value of x .

- $x = (4, 8, 16, 22.5, 45, 90, 180, 270)^\circ$

Part B: Determine $m\widehat{JKM}$.

- $m\widehat{JKM} = (4, 8, 16, 22.5, 45, 90, 180, 270)^\circ$

$$\begin{array}{r}
 13(4) - 7 = 45 \\
 \times 2 \\
 \hline
 90 \widehat{JM} \\
 360 - 90 = 270 \\
 \widehat{JKM}
 \end{array}$$

21

4. Duante bought a circular picture frame with a geometric design.

The frame has a quadrilateral inscribed in a circle.

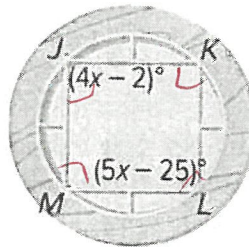

Part A: Find the value of x .

- $x = 23^\circ$

$$\begin{array}{r}
 4x - 2 + 5x - 25 = 180 \\
 9x - 27 = 180 \\
 + 27 \quad + 27 \\
 \hline
 9x = 207 \\
 \frac{9x}{9} = \frac{207}{9} \\
 x = 23
 \end{array}$$

Part B: Determine $m\angle J$.

- $m\angle J = 90^\circ$ $4(23) - 2$

Part C: What can you conclude about $JKLM$ based off your answer to Part B?

- A. $JKLM$ is a rhombus.
- B. $JKLM$ is a rectangle.
- C. $JKLM$ is a square.
- D. $JKLM$ is an isosceles trapezoid.

5. Alyssa makes earrings by bending wire into various shapes. She often bends the wire to form a circle with an inscribed quadrilateral as shown. She would like to know how she can find $m\widehat{ADC}$ if she knows $m\angle ADC$. Write a formula for finding $m\widehat{ADC}$ given that $m\angle ADC = x^\circ$.

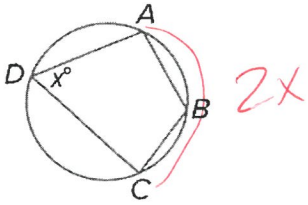

$$m\widehat{ADC} = \underline{360 - 2x}$$

3) Consider the shown below.

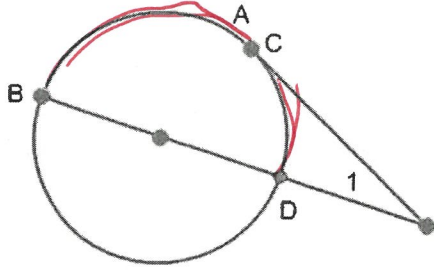

$$\frac{AB - CD}{2} = 21$$

Part A: With one color, highlight the larger intercepted arc needed to find $m\angle 1$.

Part B: With another color, highlight the smaller intercepted arc needed to find $m\angle 1$.

4) Consider $\odot A$ shown below.

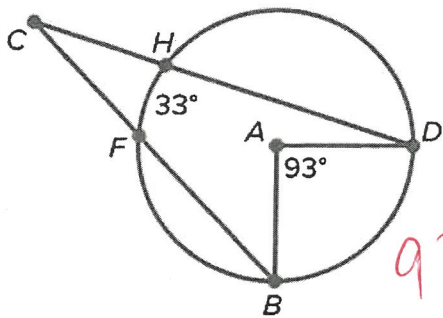

$$\frac{93 - 33}{2} = 30$$

Find $m\angle C$.

- A. 30°
- B. 33°
- C. 60°
- D. 63°

5) Find the value of x .

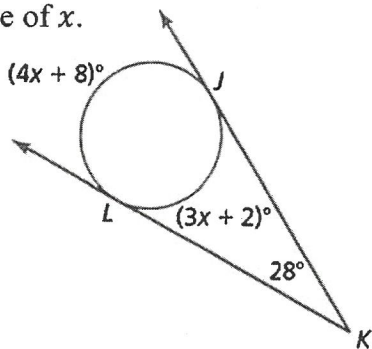

$$2 \left(\frac{4x + 8 - (3x + 2)}{2} = 28 \right)^2$$

$$4x + 8$$

$$4x + 8 - 3x - 2 = 56$$

$$x + 6 = 56$$

$$x = 50$$

$x = 50^\circ$

86. Shelley is designing a set for a play that will be on a circular stage with a backdrop that follows two radii of the circle as pictured. A person sitting in the middle of the audience (point C) will have a 34° viewing angle to the ends of the backdrop. What is the measure of the angle in the middle of the backdrop ($m\angle BAD$)?

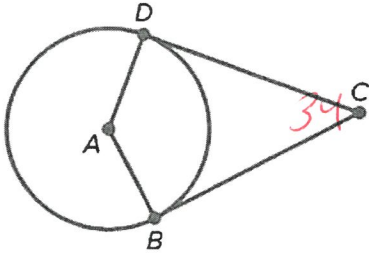

$$\frac{180}{34}$$

- The angle in the middle of the backdrop ($m\angle BAD$) is 146 $^\circ$.

87. A circle is given below with two intersecting secants, \overline{PA} and \overline{PC} .

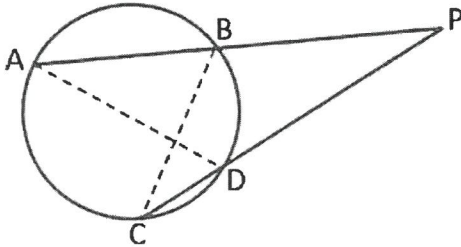

Part A: What is $m\angle BCP + m\angle P + m\angle PBC$? 180

Part B: What is $m\angle PBC + m\angle ABC$? 180

Part C: Use the substitution property of equality to write a new equality statement using Part A and B.

Part D: Solve your statement in Part C for $m\angle P$.

Part E: Use your answer to Part D, along with your knowledge of angle arc measures to prove $m\angle P = \frac{m\widehat{AC} - m\widehat{BD}}{2}$.

8.)

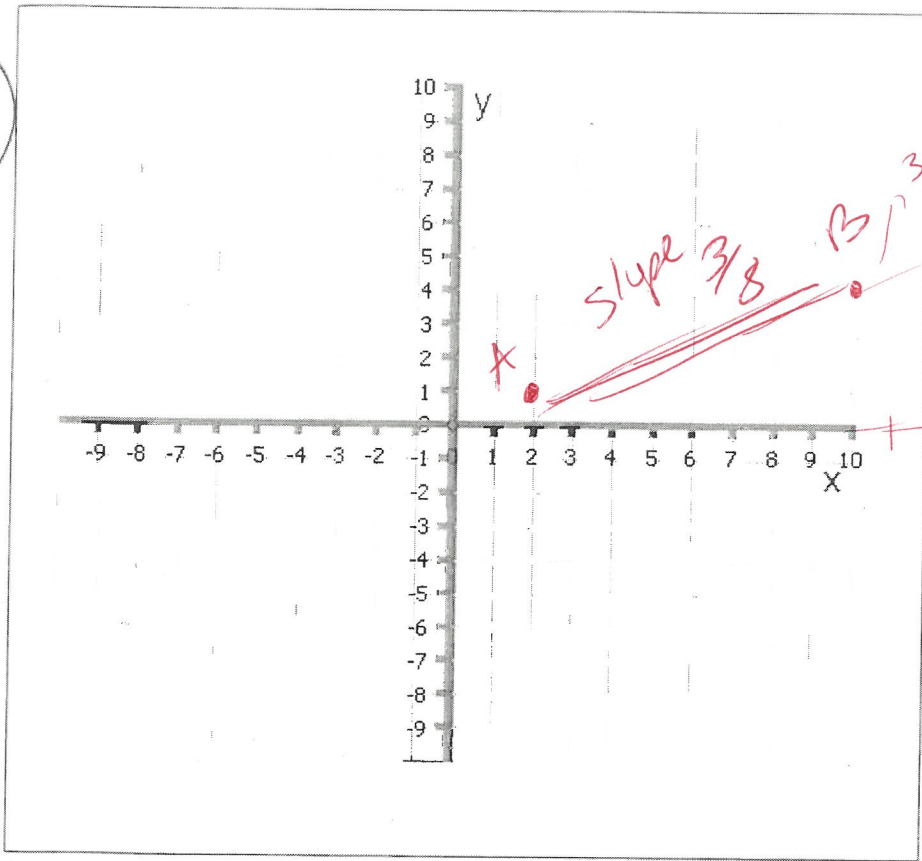

40)

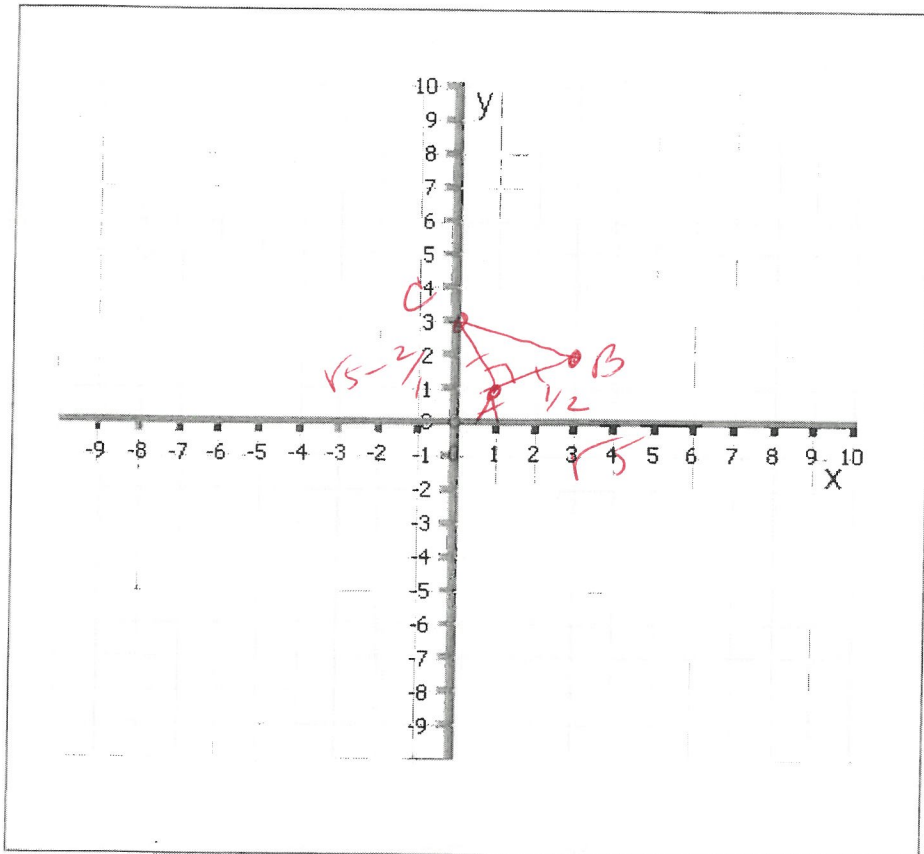

41)

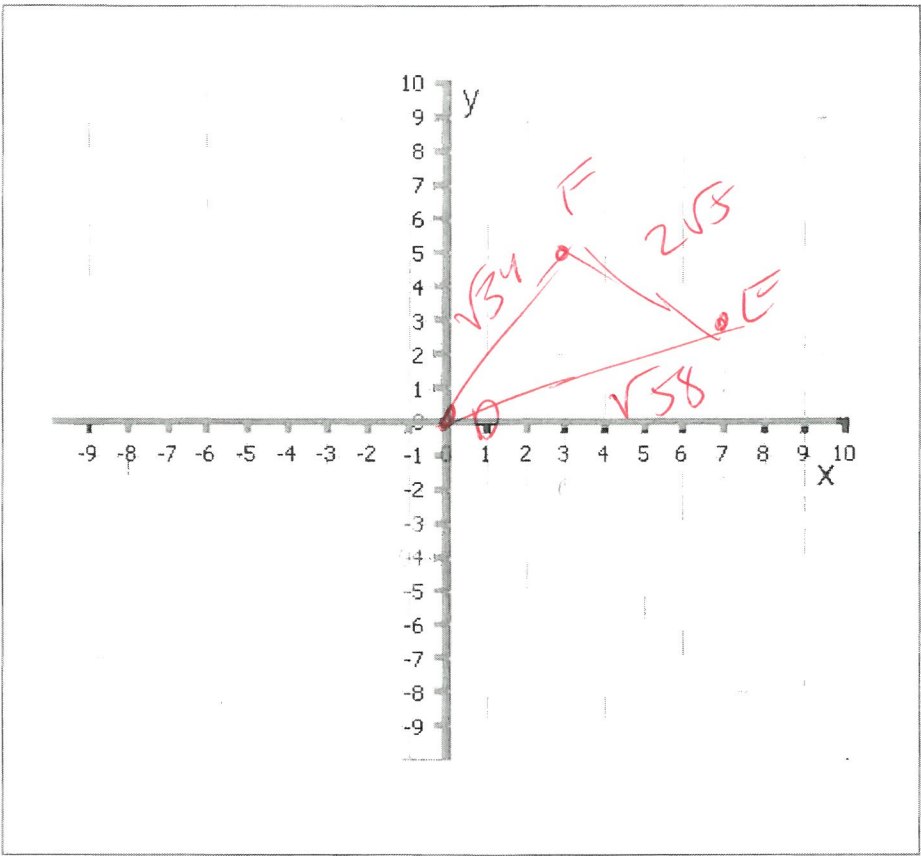

46)

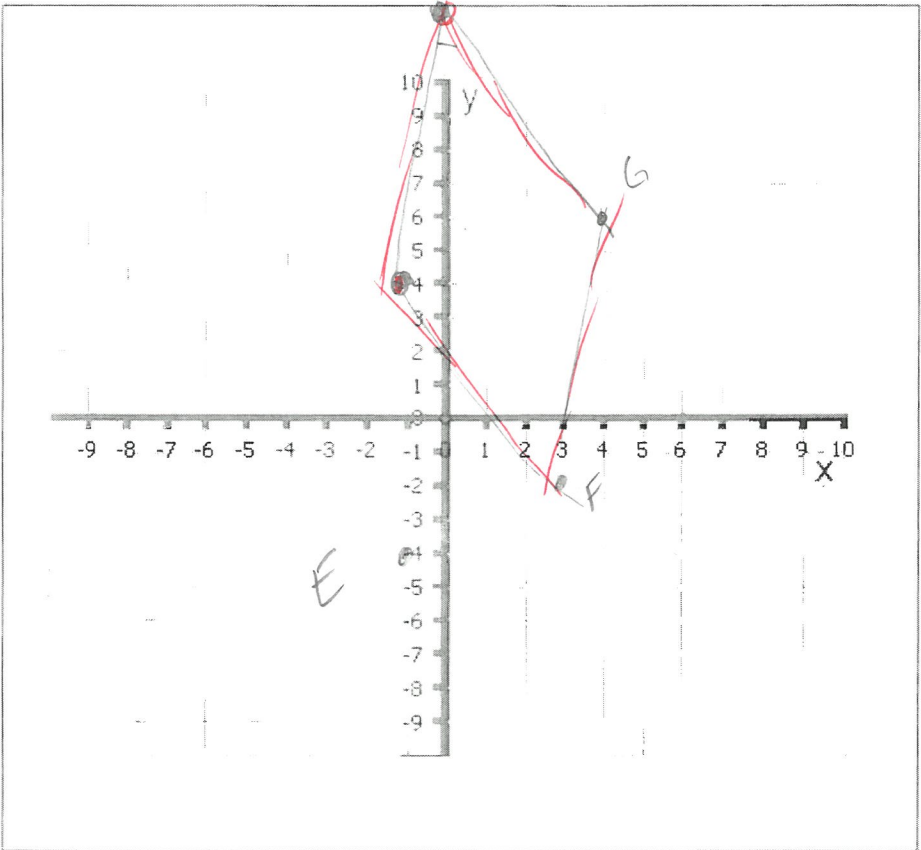

47)

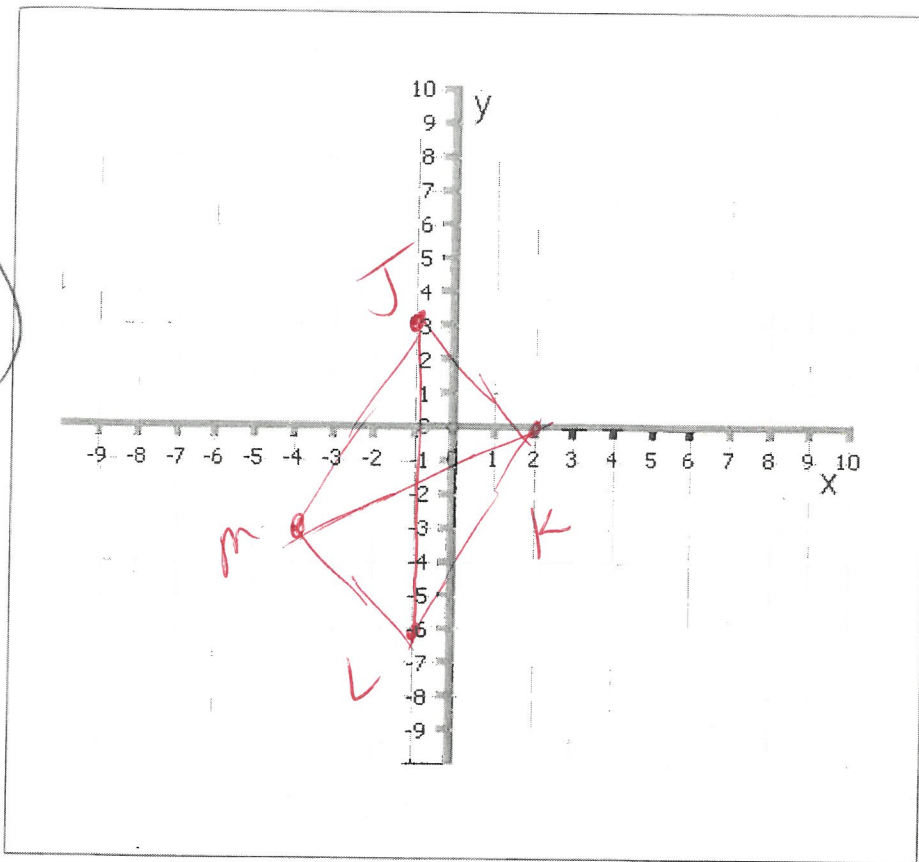

48)

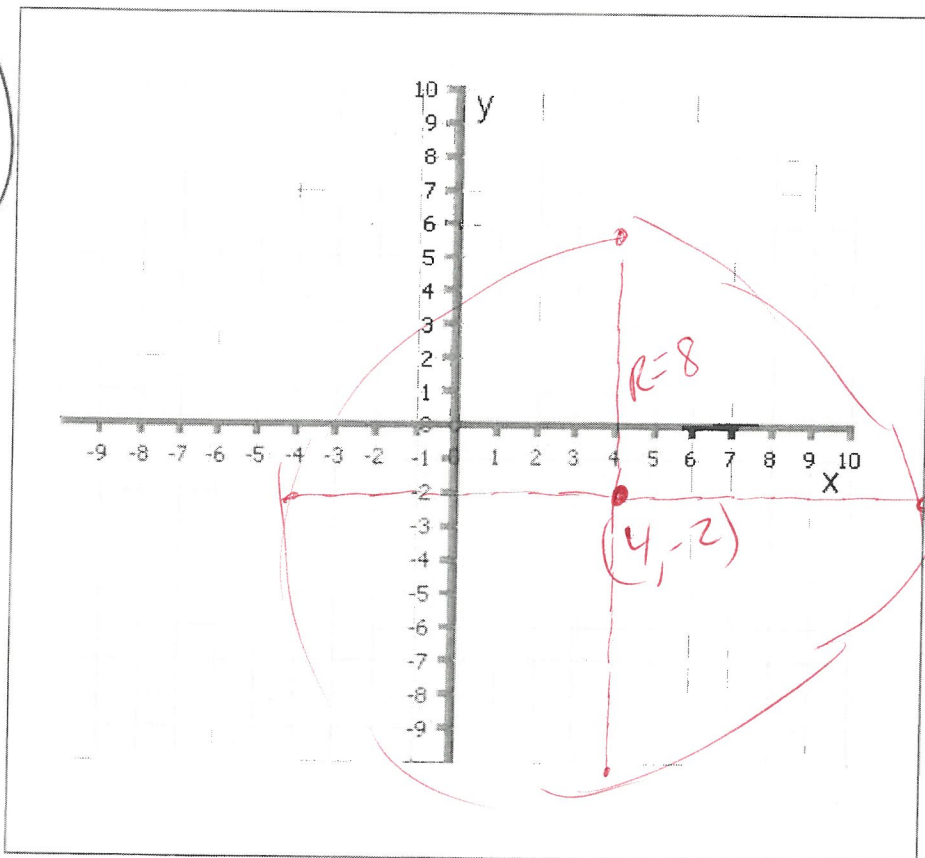

50)

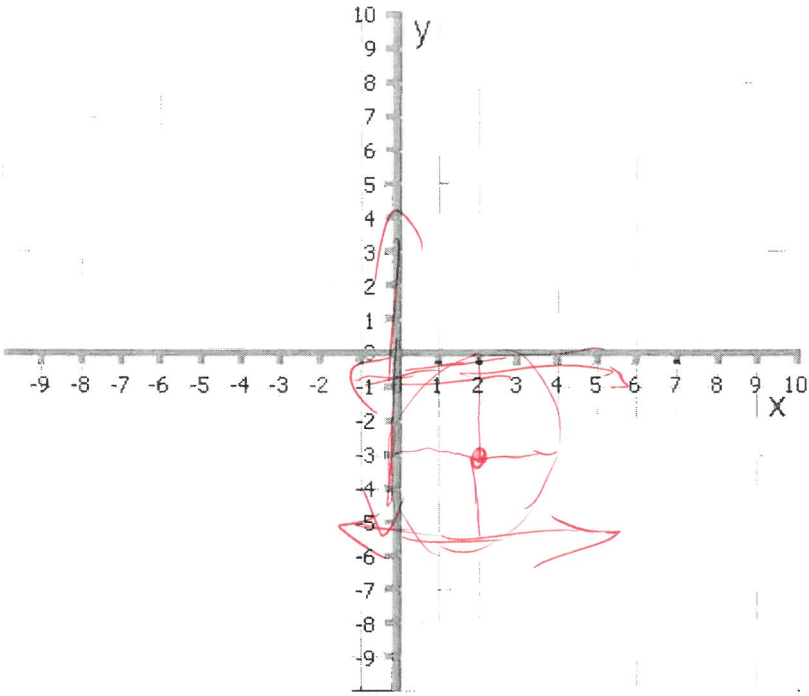

51)

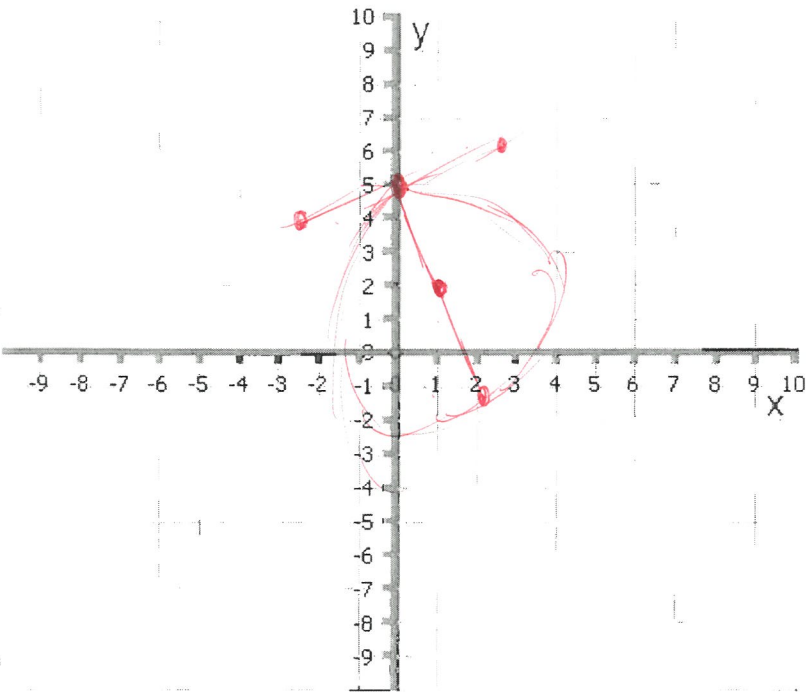

52)

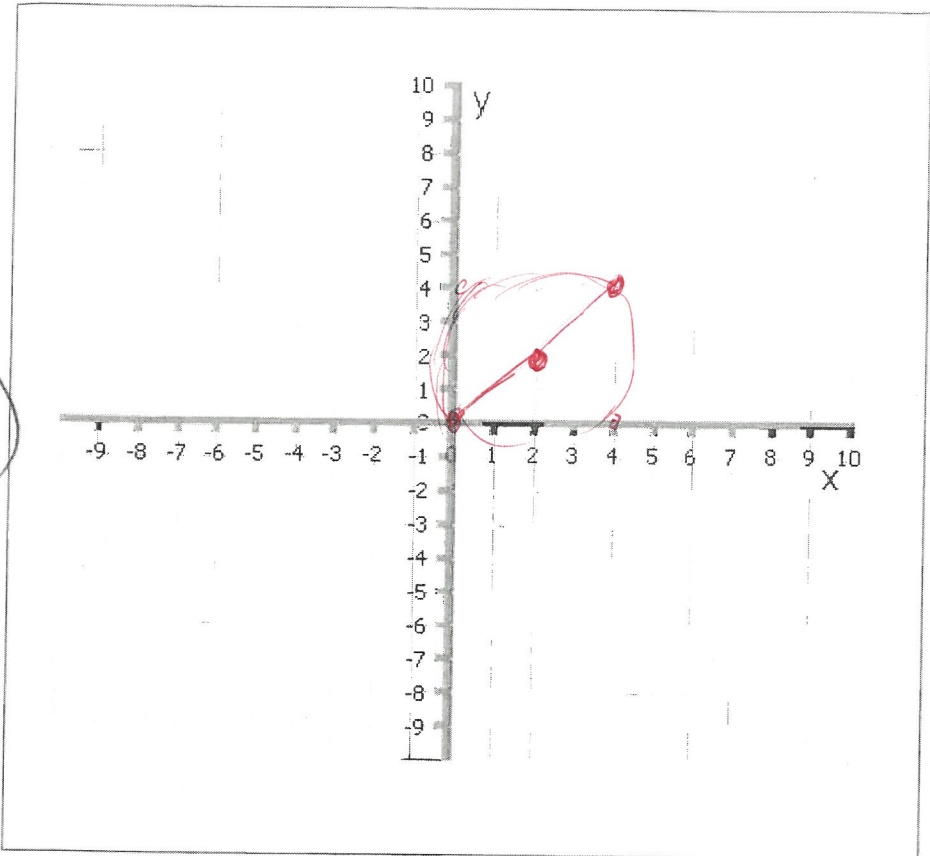

54)

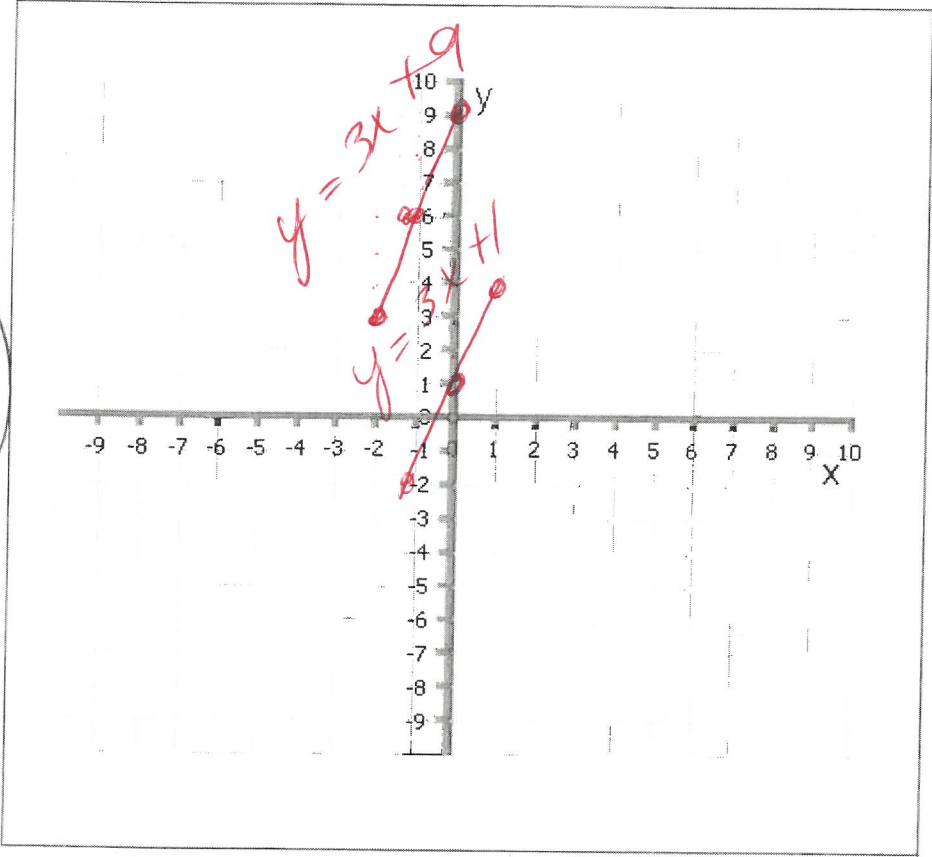

56)

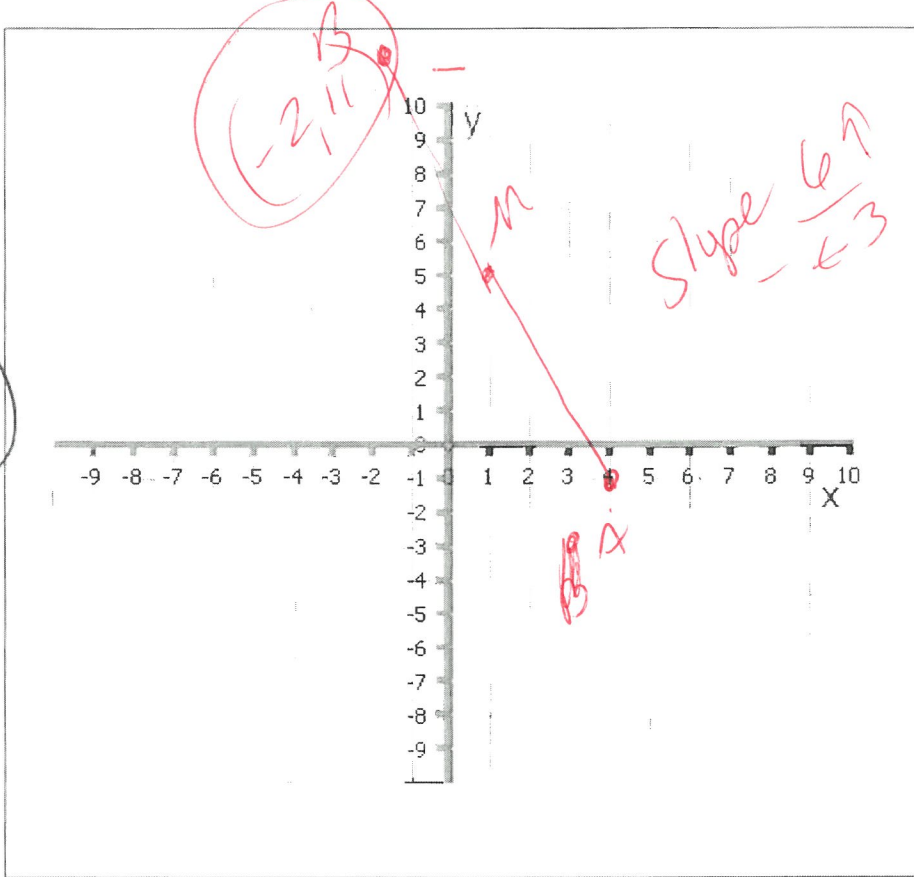

57)

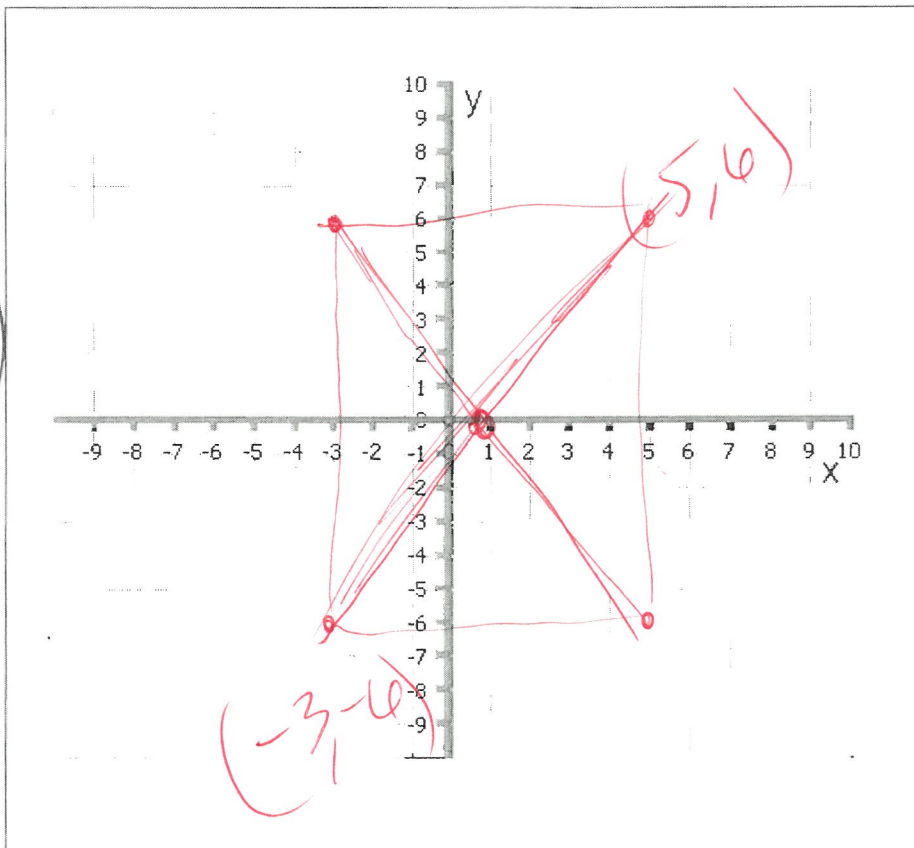

58)

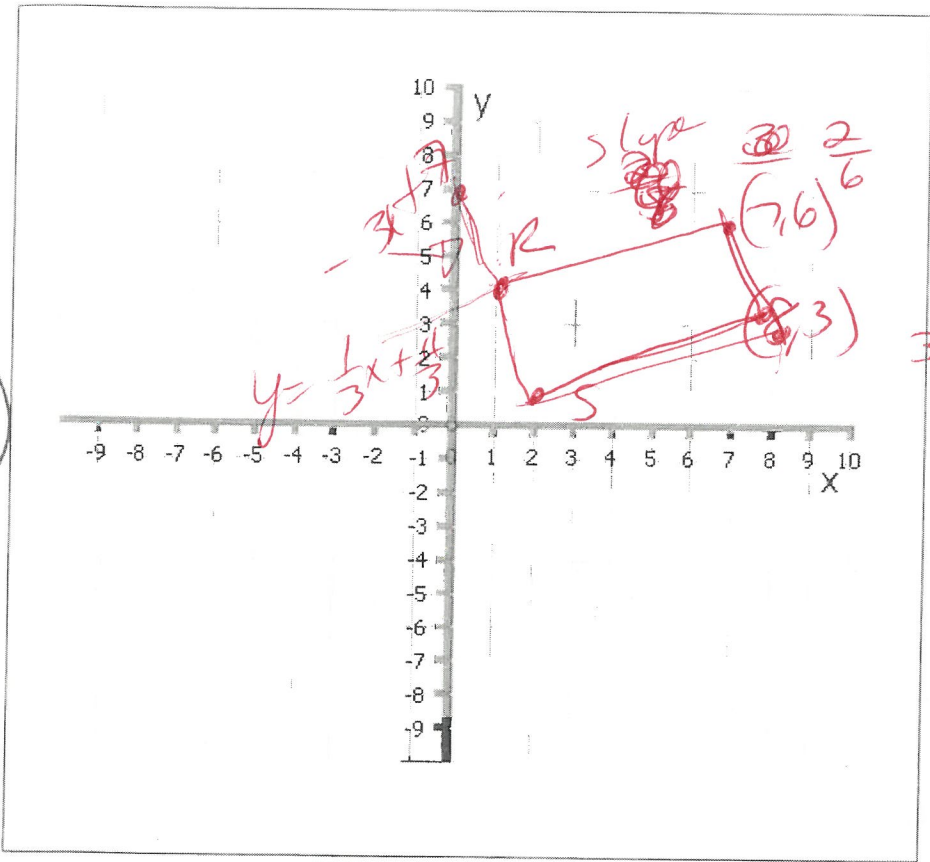

59)

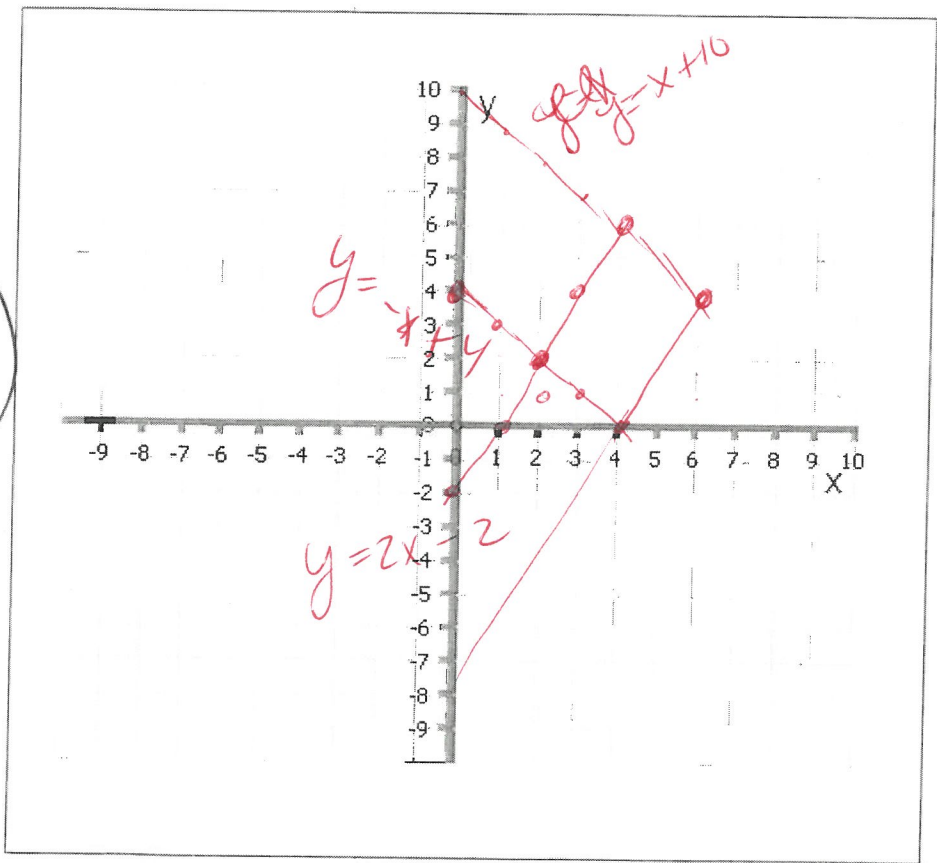

(1)

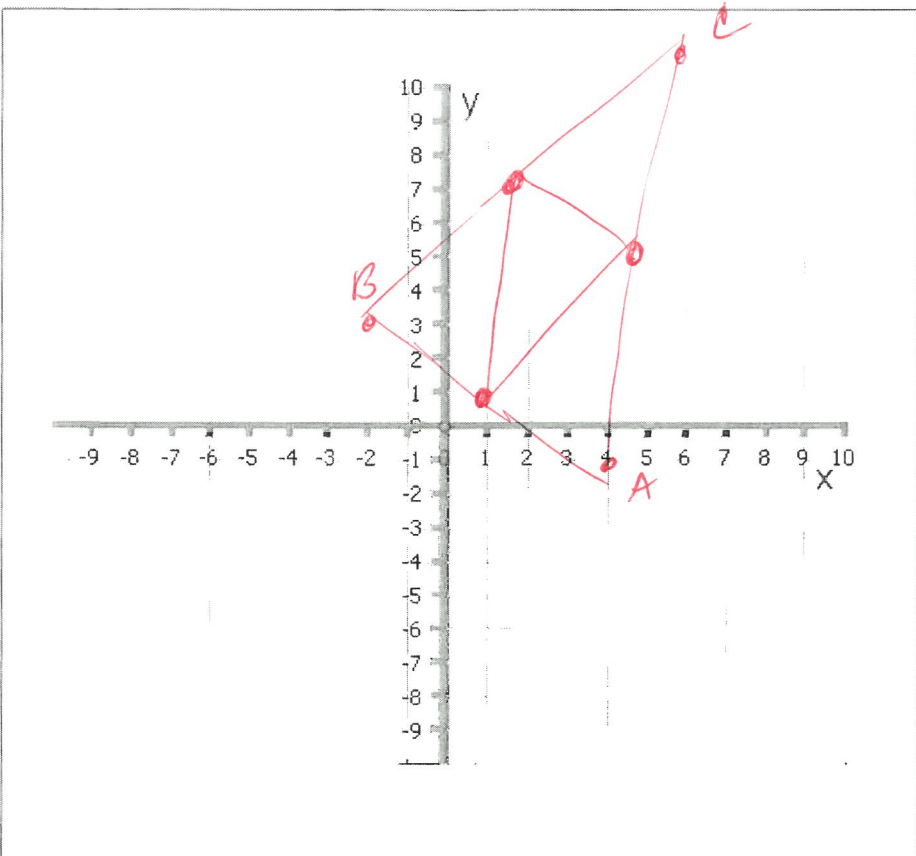

(2)

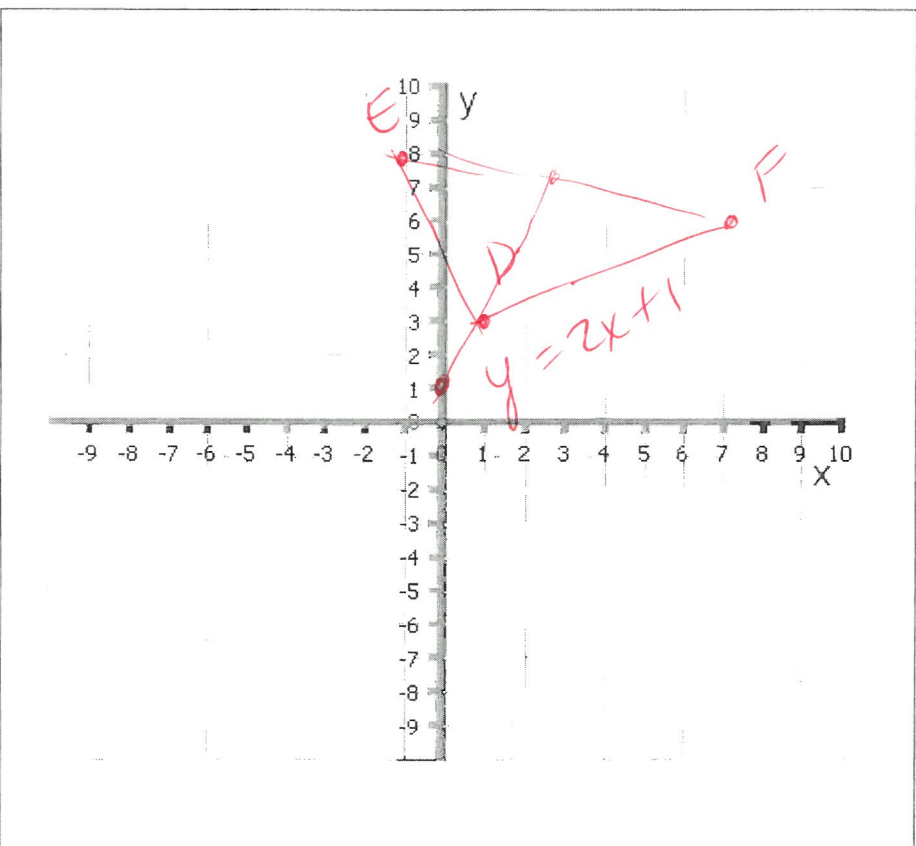

63

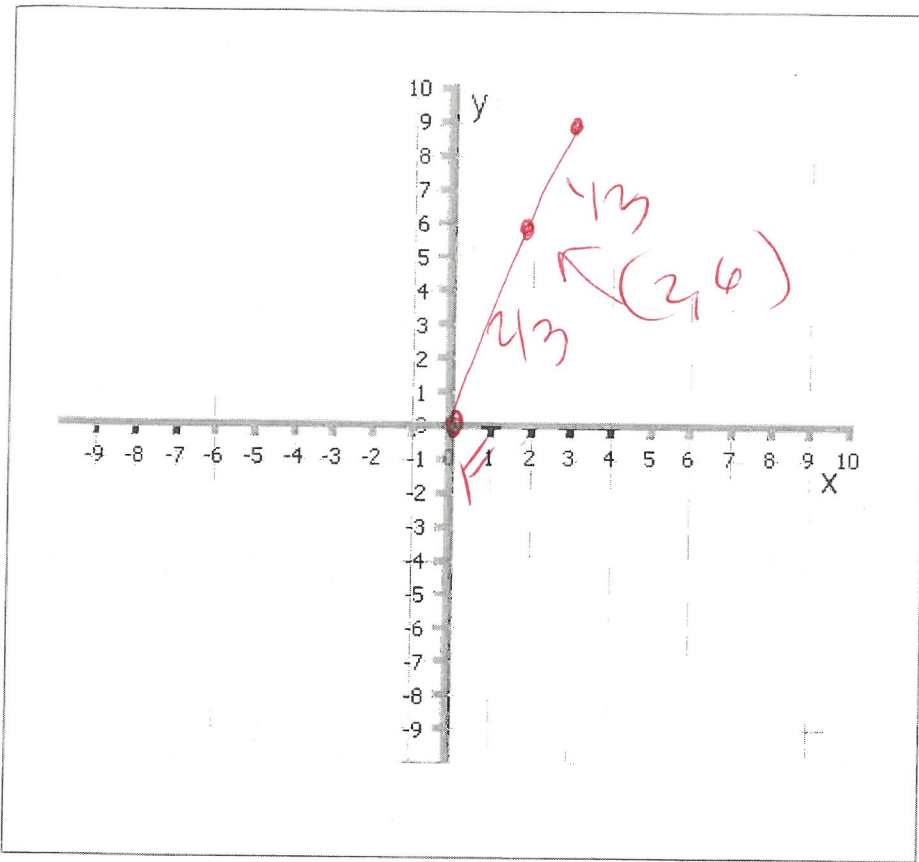

64

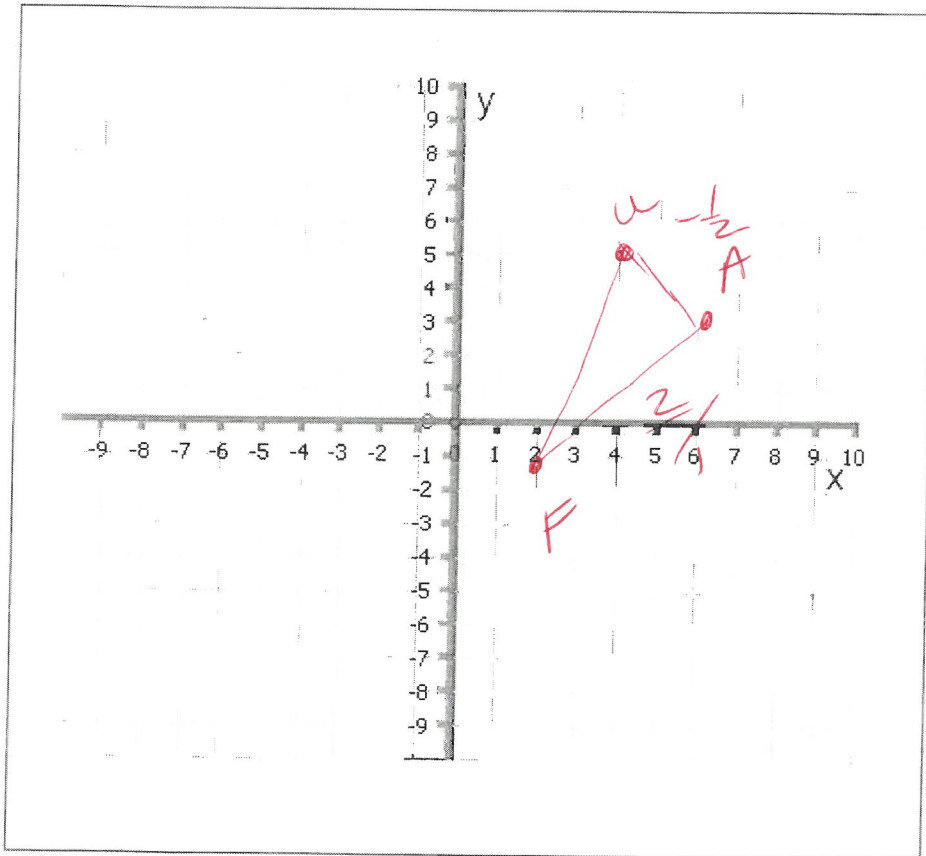

Slopes
neg.
non-parallel

$$\frac{3 - (-1)}{6 - 2} = \frac{4}{2} = \frac{2}{1}$$

$$-\frac{1}{2}$$

65

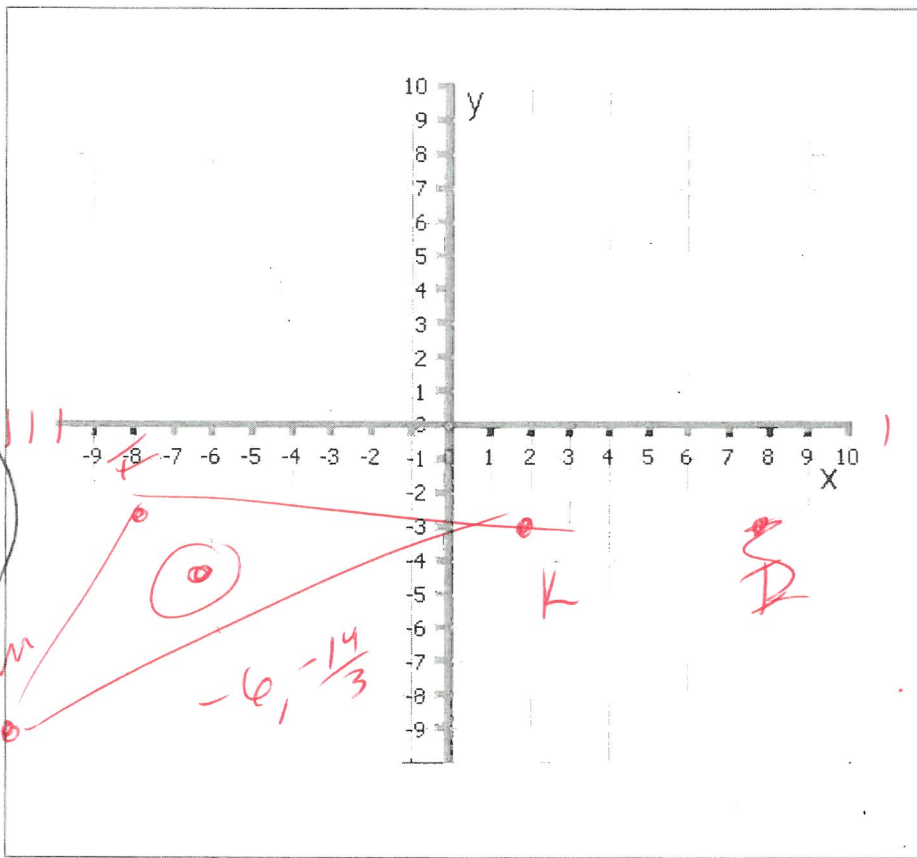

Perennial
✓ 6 115
14
16
19
20
27
29
30
31
32

7, 8, 28
38, 43, 45
53, 55
56, 57

